

Design and Development of Stab-bar Assembly Machine

Pranit Purkar¹, Dhiraj Zatke², Khushal Suryawanshi³, Chetan Shirole⁴

B.E. Student, Department of Mechanical Engineering, S.V.I.T. College, Nashik, India^{1,2,3,4}

Abstract: We are trying to improve existing method of Link assembly and clamp assembly operation in the premises of Sharda Motor Pvt.Ltd. Nashik. In this project we discuss about working of link assembly machine and clamp assembly machine. This machine performs link connecting operation and clamp pressing operation respectively. Compared with traditional method, our new design machine has remarkable advantages. It provides high quality, less time and low cost route for operation of stab bar. The effect of stab bar assembly machine is a new machine which performs the same operation as that of those two machines. Also we discussed about parts of stab bar assembly machine, there drawings on solid edge, assembly and its function. This project basically concerned with design of a new machine which perform the require operation at one place so that customer will get right delivery.

Keywords: Anti-roll bar (Stab bar), Suspension, pneumatic pressure, DED (Dual end drive).

I. INTRODUCTION

In Today's Industrial Competitions we are showing our ability with others by doing change in machine and working. The primary Element Which is use for operation is Stab-bar(anti-roll bar) are U-shaped and which is connect to two wheels i.e. left and right wheel. It is function is reducing body roll motion when vehicle is at the turning condition [1]. There are two machines namely links Assembly Machine and Clamp Assembly Machine. The parts which are use on stab bar assembly machine are stab bar, LHS links, RHS links, bolt tightner, bolts. Operation which is performed on stab bar assembly machine consists, first step stab bar is fix on machine then links (LHS and RHS) are connected at left and right hand side of stab bar. Links connect to stab bar on Links assembly machine with the help of bolt tightner. The second machine used is clamp assembly machine. Operation performed on this machine is to clamp the rubber bush on the stab bar with the help of pneumatic pressure. At the time of starting rubber bush is placed on the fixture of machine and placed the stab bar on that rubber bush and pressed the button to perform the operation. With the help of cylinder we can easily pressed the rubber bush on that stab bar. Two rubber bushes are placed at a certain distance on machine. Center distance between two rubber bushes is determined by designer [2].

II. LITERATURE SURVEY

[1] **Pravin Bharane, et.al** studied from this paper we taken functions of Stab-bar about ability to reduce the body roll. A spring rate increase in the front anti-roll bar will produce under steer effect while a spring rate increase in the rear bar will produce over steer effect. Thus, anti-roll bars are also used to improve directional control and stability. One more benefit of anti-roll bar is that, it improves traction by limiting the camber angle change caused by body roll. Anti-roll bars may have irregular shapes to get around chassis components, or may be much simpler depending on the car.

[2] **Banker Harshal, et.al** from this paper we taken inventions of anti-roll bar in automobile industry. The effect of different variable which affect the roll motion of the body.

When the anti-roll bar is used in the vehicle then reduces the body roll by 48.4 % which gives stability to the vehicle. In this paper author also used finite element method to find the stiffness of the anti-roll Bar and also show that lowest stiffness to the weight ratio is achieved by using the shortest length of side length of the bar.

[3] **J. Marzbanrad, A.Yadollahi, et.al** has studied from this paper we taken consideration about the characteristics of anti-roll bar. To improve the roll characteristics of a car, the customary approach is to increase the roll stiffness by using a stabilizer bar which affects the ride comfort with respect to high frequency isolation induced by road excitation. In order to enhance the vehicle performance, several experiences are studied.

At present one of the most efficient methods is the roll control with a semi-active suspension system in order to isolate the driver from roadway noise, road holding on irregular road surfaces and safe turning through steering.

As is the case with any vehicle system, an actual car is expected to operate in a highly variable environment. For instance, parameter variations resulting from loading pattern and driving condition will influence vehicle dynamics.

III. MACHINE DETAILS

3.1 TYPES OF MACHINES:

3.1.1 LINK ASSEMBLY MACHINE:

The Link assembly machine is as shown in Fig 3.1.1. Stab bar operates on Link assembly machine. The parts which are use on Link assembly machine are stab bar, LHS links, RHS links, bolt tightner, bolts etc. Operation which is performed on Link assembly machine consists, first of all stab bar is fix on machine then links (LHS and RHS) are connected at left and right hand side of stab bar. Links connect to stab bar on Link assembly machine with the help of bolt tightner. Vehicle anti-roll bar is part of an automobile suspension system which limits body roll angle [4]. This U-shaped metal bar connects opposite wheels together through short lever arms and is clamped to the vehicle chassis with rubber bushes [5]. Its function is to reduce body roll while cornering, also while travelling on uneven road which enhances safety and comfort during driving [2].

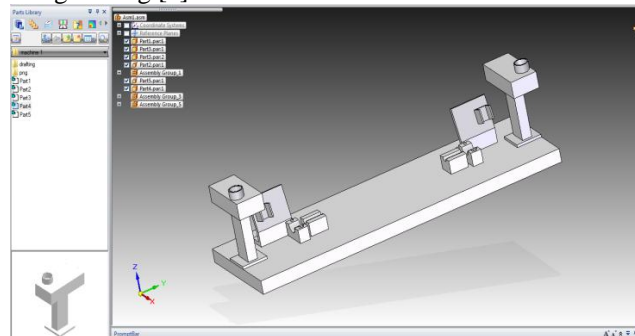

Fig.3.1.1 : Links Assembly Machine [6]

A) Working of Links Assembly Machine:

Project consists two operations which are performing on two separate machines in DED (Dual End Drive) Department [6]. Project consist two machine namely stab bar assembly machine and Clamp Assembly Machine. First operation is performed on stab bar assembly machine. Machine operator Start the Stab Bar Assembly Machine. In this operation first of all machine operator fixed the stab bar on workplace and left hand side link (LHS) is tight on left side with the help of bolt tightener. Similarly, Right hand side link (RHS) is tight on right side with the help of bolt tightener. For tightening purpose bolts are use on stab bar assembly machine. The time required for performing operation on stab bar machine is about 2 minute 15 sec. to 2minute 30 sec. [6]

3.1.2 CLAMP ASSEMBLY MACHINE:

After completion of operation on stab bar assembly machine. The stab bar is move on clamp assembly machine. On the clamp assembly machine with help of c-clamp, rubber bush is Clamp on stab bar.

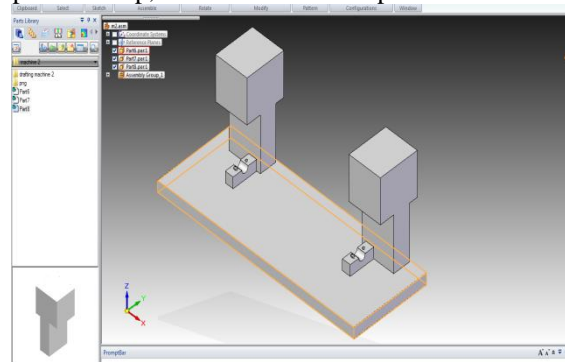

Fig. 3.1.2: Clamp Assembly Machine [6].

B) Working of Clamp Assembly Machine:

After Completion of operation on Stab bar Assembly Machine, stab bar is transfer to Clamp Assembly Machine through Conveyor. Clamping Operation is done with the help of clamp assembly machine. Machine operator on clamp assembly machine fixed the stab bar on clamp assembly machine. Two Pneumatic cylinders are used in the clamp assembly machine. With the help of Pneumatic pressure rubber bush is clamp on a stab bar [3]. In this operation Rubber bush is clamped at center distance on both sides with the help of C-clamp. After the completion of this operation the stab bar is marked for final inspection by the same machine operator. After that stab bar is move to another department through conveyor. Time required for performing operation on Clamp assembly machine is about 50 sec. to 55 sec [6].



IV. DESIGN OF STAB BAR ASSEMBLY MACHINE:

According to sponsors requirement we want to design new machine which performs same operation as that of link assembler machine and the clamp machine. Time required to perform the first operation on link assembler machine is approximately 2 minute 15 seconds to 2 minute 25 seconds and time required to perform the second operation on clamp machine is approximately 1 minute 15 seconds to 1 minute 20 seconds [6]. The machine which we design is required time to perform both the operations is approximately is about 2 minute 45 seconds to 3 minutes. Space required for link assembler machine and clamp machine is definitely more than single machine. The machine which we design is single machine which required very less space machines namely link assembler machine and clamp machine. So, with the design of new machine we will get not only the benefit of efficient operation but also reduction in time and reduction in space. The Globalization has laid to the opening up of local markets to global competitions. This has brought a fundamental change in new product development philosophy. The manufacturer should be capable of developing a high quality, low cost product in short time duration with aim of customer satisfaction.

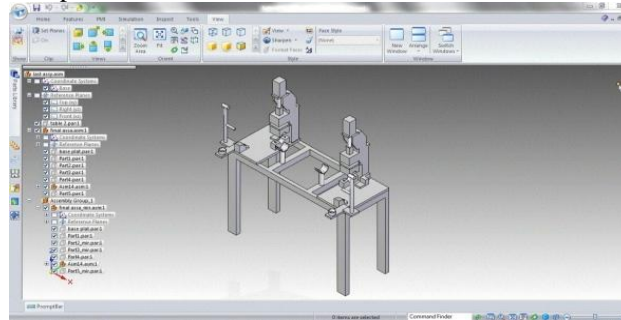

Fig IV : Stab bar Assembly Machine [6].

Our project is performing in DED (Dual End Drive) department [6]. As our sponsor is vendor of Mahindra and Mahindra they want to complete their targets within their time period / deadline. So, the main aim of our project is to manufacture maximum stab-bar within given period of time and with the solution of our project we can achieve this. The machine will deal with reduce the human labor as well as time of processing, also required small space area. In link assembler machine operator tight the links at the right hand side and left hand side of the stab bar with the help of bolt tightened. After that stab bar is move on second machine i.e. clamp machine. In clamp machine operator tight the rubber bush on stab bar at the certain definite distance with the help of cylinder, for these operation C-clamp used [3]. For these processes three operators are required because of which there is a problem of production cost is more and manufacturing time is also more. To overcome this problem we will design new machine with the help of which a single operator will handle both the operations efficiently.

V. ANALYSIS OF MACHINE TIME:

Table I : Link Assembly Machine:

Sr.No.	Operations	Time (sec)
1	Stab bar rod take from trolley and put on Link Assembly Machine.	30
2	Take links and bolt from basket.	15
3	Attach the link on both sides of stab bar rod with help of bolt by using bolt tightner.	20

Table II : Clamp Assembly Machine:

Sr.No.	Operations	Time (sec)
1	Take Stab bar rod from Link Assembly Machine and put on trolley.	08
2	Attach Rubber bush on Rod with help of hand.	15
3	Then take Rubber bush attached rod on clamp assembly machine from trolley.	07
4	Take Clamp from basket and put on notch of clamp assembly machine.	08
5	Press operation	12
6	Ready stab bar keep on trolley	05

Table III : Stab bar Assembly Machine:

Sr.No.	Operations	Time (sec)
1	Stab bar rod takes from trolley and put on Stab bar Assembly Machine.	30
2	Take links and bolt from basket.	10
3	Attach the link on both sides of stab bar rod with help of bolt by using bolt tightner.	20
4	Take Rubber bush from basket and attached to the stab bar rod.	10
5	Rod put on second operation place.	02
6	Take clamp from basket and put on notch.	03
7	Press operation	12
8	Ready Stab bar rod keep on trolley.	03

5.1 Total Time Required for Machines:

- i) Link Assembly Machine : 65 sec
- ii) Clamp Assembly Machine : 55 sec
- iii) Stab bar Assembly Machine : 90 sec

VI. RESULT AND DISCUSSION

Table 4: Stab bar Assembly (NEW) Machine

Sr.No.	Machines	Time (sec)
1.	Total time required for Link Assembly Machine and Clamp Assembly Machine.	120
2.	Stab bar Assembly (New) Machine.	90
3.	Total Time Saving by using (New) Stab bar Assembly Machine.	30

The main goal of using Stab bar Assembly Machine is Working speed should be increases of machine. Product cost should be less, Required less human labour. Required less processing area. Machines user interface should be as simple as possible. Machines should produce quick and accurate results. A proper authentication should be used by the Machine.

VII. CONCLUSION

In this project we have discussed about operations to be performed on the stab bar assembly machine and c-clamp machine. By designing new machines which perform the same operation on the stab bar we can reduce the time of operation and also we can reduce the labour cost. Compared with traditional method, the technique has remarkable advantages. It increases the productivity of the company, it also reduces the number of machine operators, and indirectly it reduces the labour cost of the company. The one of the main benefit is machine operator can perform the operation at one place without any difficulty. Also we discussed about details of machine and their parts required, there drawings on solid edge, assembly and it's working.

ACKNOWLEDGMENT

With deep sense of gratitude we would like to thanks all the people who have lit our path with their kind guidance We remain indebted to **Prof. V.M.Rane (H.O.D, Mechanical Department)** for their timely suggestion and valuable guidance. We are very thankful to our guide **Prof. P.N.Wakchaure**for his invaluable guidance and constant source inspiration. We are also obliged to **Mr. Sandip Khade (GM) &Mr. Sachin Dixit (SR. Production Manager) Also Mr. Manoranjan Patra (HR), SHARDA Motors Pvt. Ltd, Nashik** for sponsoring our project. The special gratitude goes to H.O.D, staff members, technical staff members, of Mechanical Department for his expensive, excellent and precious guidance in completion of this work.

REFERENCES

- [1]. Pravin Bharane¹, Kshitijit Tanpure², Amit patil³, Ganesh Kerkal⁴, "Design, Analysis and Optimization of Anti-Roll bar". Int.Journal of Engineering Research and Applications, Vol. 4, Issue 9, September 2014.
- [2]. Bankar Harshal¹, Kharade Rushikesh², P. Baskar³, "Finite Element Analysis of Anti-Roll Bar to Optimize the Stiffness of the Anti-Roll Bar and the Body Roll," –International Journal of modern Engineering research (IJMER). Vol-4, Issue-5, May 2014.
- [3]. J. Marzbanrad¹, A. Yadollahi², "Fatigue Life of an Anti-Roll Bar of a passenger Vehicle" World Academy of Science, Engineering & Technology -Vol.6, February-2012.
- [4]. Preetam Shinde¹, M.M.M.Patnik², "Parametric Optimization to Reduce Stress Concentration at Corner Bends of Solid and Hollow Stabilizer bar" International Journal of Research in Aeronautical and Mechanical Engineering Vol. 1, Issue 4, August 2013.
- [5]. Jinlong Wang¹, Aiping Zhang², Liang Zhu³, "Optimization Design of Rear Stabilizer Bar for WF-Model Based on CAE" International Journal of u-and e- Service, Science and technology -Vol.6, No.5, May-2013.
- [6]. Sharda Motor's Pvt. Ltd Company's Assembly Machines handbook.

BIOGRAPHIES

Pranit Purkar is working as student & currently taking his Bachelor's degree from S.V.I.T. College of Engineering, Nashik which is affiliated by Savitribai Phule Pune University.



Dhiraj Zatke is working as student & currently taking his Bachelor's degree from S.V.I.T. College Of Engineering, Nashik which is affiliated by Savitribai Phule Pune University



Khushal Suryawanshi is working as student & currently taking his Bachelor's degree from S.V.I.T.College Of Engineering, Nashik which is affiliated by Savitribai Phule Pune University.



Chetan Shirole is working as student & currently taking his Bachelor's degree from S.V.I.T.College Of Engineering, Nashik which is affiliated by Savitribai Phule Pune University.