



# Tractor Driven Soil Filtering Machine

Aniket Gadhave<sup>1</sup>, Sanket Nirbhavane<sup>2</sup>, Ashish Kothawade<sup>3</sup>, Tejas Pardeshi<sup>4</sup>, S. V. Dawange<sup>5</sup>

Under graduate students, Gokhale Education Society's, R. H. Sapat College of Engineering, Management Studies & Research, Nashik, Maharashtra, India.<sup>1234</sup>

Assistant Professor, Gokhale Education Society's, R. H. Sapat College of Engineering, Management Studies & Research, Nashik, Maharashtra, India.<sup>5</sup>

**Abstract:** Agriculture in India is unique in its characteristics, where over 250 different crops are cultivated in its varied agro-climatic regions, unlike 25 to 30 crops grown in many of the developed nations of the world. Soil filtering is done so as to remove stones from farm which are not intended for farming operations. Also, soil filtering for harvesting potatoes is a major activity that involves digging potatoes from farms i.e. harvesting after they are fully grown. It can also be used for harvesting various crops, mainly potatoes, turmeric, ginger, etc. Potato is considered as one of the most important vegetable crops in India. Potato is cultivated for self-consumption and also for commercial purposes. Potato harvesting as of today in the country is labour intensive and tedious. Most Indian farmers harvest potato manually. Mechanization of potato harvesting by machine especially by tractor in large area will greatly reduce the drudgery involved and also complete the work in less time and is economically cheap. However, it was never introduced in India and hence a study on its performance is imperative to promote this technology. Soil filtering machine driven by tractor will thus introduce mechanized farming to reduce man power & time for each harvest. Thus, a soil filtering machine was designed and developed which is driven by small tractor (less than 30HP). It is connected with the three-point hitch at the back of tractor. Power to run the device was taken from PTO shaft of tractor. The transmission system was from PTO to oscillating net by, bevel gear box, shaft and pulleys. Computerized model of the machine was designed in Dassault Systems CATIA V5. The device was tested on the field with various advance speed.

**Keywords:** Potato, Small tractor, Soil filtering, Design in CATIA.

## I. INTRODUCTION

Soil filtering is primarily done for filtering stones from soil which are not intended in farming. It can also be used for harvesting various vegetables & crops, mainly potatoes, turmeric, ginger, etc. Soil filtering for harvesting potatoes is a major activity that involves digging potatoes from fields once they are fully grown. Potato (*Solanum tuberosum*, L.), the 4<sup>th</sup> largest crop of India in terms of area and production, is grown in about 1.2 million hectares and has production and productivity of 22.1 million tonnes and 18.2 t/ha, respectively. The average annual growth of about 6% in potato in the last 30 years in India can be attributed to the availability of improved varieties, better availability of quality seed, standardization of agronomic practices and mechanization of potato cultivators. Potato digging is a cumbersome process as soil-potato ratio is 31:1 and requires 600 man-h/ha if done manually. Hence it is labour intensive and tedious. Most Indian farmers harvest potato manually and only a few with power tiller attached potato diggers. Mechanization of potato harvesting by machine especially by tractor in large area had greatly reduced the drudgery involved and also completed the work on time and was economically cheap. However, it was never introduced in India and hence a study on its performance is imperative to promote this technology. A number of animal drawn and tractor mounted tools and equipment's have been developed for digging operation. In India, early crop is harvested manually with khurpa. Many progressive farmers are adopting a row spacing of 686mm instead of 610mm. Popular tools for digging are animal drawn plough-type digger and tractor operated plough-type digger. In both these, exposure of tubers is not satisfactory and repeated picking is required for the leftover tubers. Digger elevator is a good machine for mature crop but causes lot of bruising while digging early potatoes.

## II. MATERIALS AND METHODS

Design philosophy: The design considerations for the development of soil filtering machine were:

- It should be suitable for low horse power (18-25 hp) tractors, which are popular among small farmers.
- Equipment should be multipurpose one i.e. suitable for,
  - Row-to-row spacing of 610 mm (24 inches) to 710 mm (28 inches) and,
  - Harvesting potatoes, turmeric, ginger, etc.
  - Early crop without haulms cutting and main crop after haulms cutting.
- It should have field capacity of 1.5-2.0 ha/day so that crop harvesting period is reduced and late digging in dry field conditions is avoided.



- It should be simple in construction, easy to operate and inexpensive to maintain.
- It should be robust enough for digging under dry field conditions.

Construction: Tractor driven soil filtering machine (Fig. 1) consists of following parts:

Part	Material
Three point hitch system	65 x 10 mm flat (MS)
Frame	40 x 40 x 3 mm box (MS)
Filtering net	60 x 40 x 3 mm box (MS) 12 mm diameter rod (MS) 50 x 5 mm flat (MS)
Bevel gearbox	230 x 230 x 180 mm box
Pulley	160 mm diameter (MS) Reduction ratio – 1:2 (CI) 50 mm Diameter (MS)
Shaft	Reduction ratio-1:2(CI)
Blade	8 mm Flat (MS)

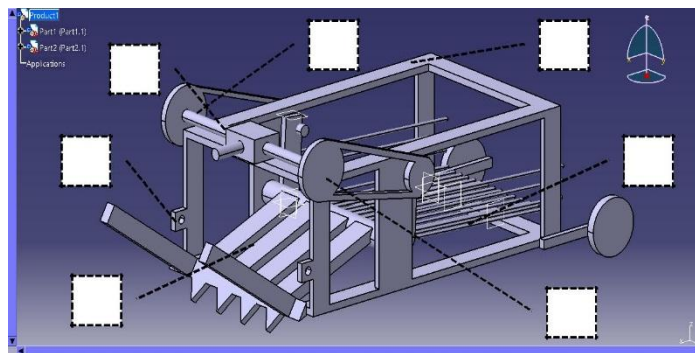

Fig. 1 Tractor driven soil filtering machine

Overall length, width and height of the machine are 1290 x 930 x 580 mm respectively. As shown in Fig. 1 three point hitch system (part no. 1) is of standard size and shape. A frame (part no. 2) of 1290 x 930 x 580 mm is welded together as seen. The filtering net (part no. 3) is welded together and the distance between two rods is kept as that of average size of potato, roughly 50 mm centre-to-centre. The gears i.e. pinion & crown of the bevel gears (part no. 4) are of equal sizes thus keeping reduction ratio as 1:1. Pinion is connected with PTO shaft of the tractor whereas crown is mounted on another shaft (part no. 6). Two pulleys (part no. 5) are attached on either side of the shaft and are connected with pulleys attached with shaft connected to filtering net. The blades (part no. 7) attached at an angle of 15-20° depending of the depth needed. Working: The machine works using mechanical power from the tractor and transmits in the following way:

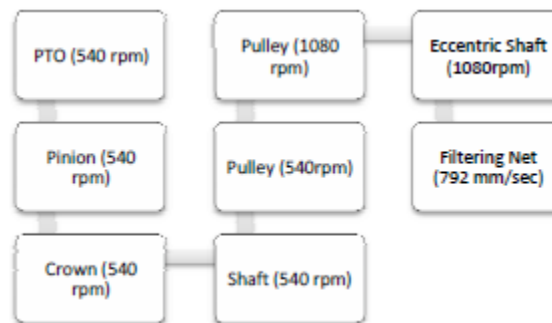

Fig. 2 Power transmission flow

The rotational motion of the eccentric shaft is converted to transverse oscillating motion of the filtering net thus used for filtering soil.

### III. OPERATIONS

The potato crop was is normally harvested manually with the help of khurpa/kudali and collected side by side. The



operation requires a group of labour to cover the field and this process is extremely slow. After harvesting, two to three operations by bullock drawn desi plough are performed to check for any tubers and were collected manually. This was the conventional method of potato harvesting. Payment in this method was made in terms of produce (about 1 2 kg man-day). Damage to the tubers by manual harvesting by khurpa/kudali is often observed.

In this method, the potatoes were sown by tractor mounted potato planter rigger at row to row spacing of 600 mm so that wheel may run through the furrows without disturbing the ridges on which potatoes were grown. The area of field was 1.0 ha. Tractor was driven with soil filtering machine on between the rows with wheels running through the furrow without disturbing the plant. The tractor was operated at forward speed of 3.5 km/h (first pass) and 6 km/h (second pass), respectively. The higher speed in second pass was selected to bring out covered potatoes on the soil surface. The tractor was operated for few rows for third pass at 8 km/h speed to check the left potato in the soil.

At first the machine is lowered by the hydraulics of tractor and is slowly move forward, the blade would then penetrate the soil and lift the soil with tubers and would dump it into the filtering net. The filtering net would continuously oscillate by the transmission system connected from the PTO, the oscillatory motion was given through eccentric shaft in system, the shaft of the eccentric motion was mounted through 2 numbers of bearings on left side and 2 numbers on right side of the elevator frame.

The continuous oscillation of the net filters the soil from potatoes. The soil falls below from the gap between the rods of the net whereas the crop travels to the back and is collected in a pan attached below or directly falls on the ground. These are then collected and transported to the storage.

#### IV. RESULTS

The percentage of mechanical injuries rose by the impact of potatoes on plates but their values were low. The average of damaged potatoes was got 4%. Following limitations for set operation got at field experiments. The blade slope cannot be more than 15°. More slopes than 15° cause soil and tubers accumulation at front of the blade. Increasing machine speed and the ploughshare angle led to a dangerous accumulation of soil in front of the blade. The problem of penetration in soil was observed at slopes less than 10°. Advance and rotational speed cannot be considered more than 4 km/h and 25 rpm. System required power was calculated as 5.5 hp and entered soil into set as 227 ton/h.

#### V. CONCLUSION

Based on discussions it may be concluded that tractor operated soil filtering machine was economically cheaper as compared to manual digging by khurpa/kudali. It also saves time for harvest of each crop by a considerable amount. The cost of operation of tractor with filtering machine has been calculated as Rs.150-175 per hectare with 18-24 hp tractors considering fuel and other charges.

Advance speed, rotational speed and blade slope is recommended as follows according to computer simulation studies and field results:

- 1) Advance speed was 1.5-3 km/h
- 2) Linear velocity of oscillating net was 690mm/sec
- 3) Blade slope was 10-15°

#### REFERENCES

- [1]. Hyde G.M., 1986 - Solid and perforated rotary blade performance on a potato harvester. ASAE Paper No.86-1557
- [2]. Muhammad Y., Mehmood A.M., Rehman R., 2003 – Design development and performance evaluation of rotary potato digger. AMA, 34(2): 43-46.
- [3]. Singh, Sukhwinder and Manjit Singh. 1997. Potato elevator digger-performance of different designs. In: Proc. 33rd Annual Convention of Indian Society of Agricultural Engineers, Sept. 21-23, Ludhiana. pp. 28.
- [4]. R.D. Singh', H.M. Singh' and R. D. Singh, Comparative performance of potato digger elevator with conventional method of harvesting at farmer's fields"
- [5]. P. Azizi, N. Sakenian, Dehkordi, R. Farhadi; Design, construction and evaluation of potato digger with rotary blade, Cercetări Agronomice în Moldova Vol. XLVII, No. 3 (159) / 2014