

PC Based Oscilloscope Using Processor

Seema Kakade¹, Dr. S. S. Lokhande²

ME Student, E&TC Department, Sinhgad College of Engg, Pune, India¹

Professor, E&TC Department, Sinhgad College of Engg, Pune, India²

Abstract: An oscilloscope, previously called an oscillograph, and informally known as a scope, CRO or DSO is a type of electronic test instrument that allows observation of constantly varying signal voltages. All are in hurry and needs gadgets follow our moves with minimum cost. A gadget that will be easily carried from one place to another and work efficiently as an oscilloscope. An oscilloscope using PC or laptop instead of carrying another gadget. The idea is to monitor the signal and it is implemented by first making signal conditioning on given signal, give it to good sampling rate and high resolution ADC. The ADC will send data to the raspberry pi, high speed processor. This Raspberry will read the data and by creating GUI and further processing is carried out for displaying data on display.

Keywords: Probe, Bit scope micro Model 5, USB interfacing with Raspberry Pi, GUI software in Python.

I. INTRODUCTION

Using Raspberry pi a credit card size computer manufactured and designed for embedded software able to construct a hardware for measurement of signals which can fit common electronic measurement and test requirements. More and more experiments are now PC assisted. Also conventional acquisition systems are very expensive.

Now-a-days, computer is not only a luxury but also a necessity for every person in today's world. Raspberry pi is a credit-card sized computer aimed at providing a computer to every person in the world. Raspberry Pi is intended to provide a base on which kids can learn programming while enthusiasts can do different types of commercial programming. It serves as an efficient base due to its low cost and the number of interfaces available. The Raspberry Pi can be used instead of a personal computer, but with some limitations due to its limited processing power. The Raspberry Pi computer does not have a way to read analog inputs. It's a digital-only computer. Analog inputs are handy because many sensors are analog outputs, so we need a way to make the Pi analog-friendly. Selecting the proper ADC for a particular application appears to be a formidable task, considering the thousands of converters currently on the market.

A direct approach is to go right to the selection guides and parametric search engines, such as those available on the Analog. Devices website. Enter the sampling rate, resolution, power supply voltage, and other important properties, and hope for the best. But it's usually not enough. A perfect companion for Raspberry Pi is Bit Scope Model 5. Bit Scopes are USB powered by Raspberry Pi. Like the Pi itself, these Bit Scope is very low power device. The Bit Scope Library is also available to create your own embedded test, measurement or data acquisition applications using Bit Scope and Raspberry Pi. Program in C/C++, Python or Pascal using an programming API. Here is a waveform capture example in python that reports on Bit Scope capabilities. High speed mixed signal data acquisition is on Raspberry Pi.

II. SYSTEM DESIGN

Block diagram and Description

The block diagram consist of 2 channel input probe, micro bit scope model 5, Raspberry pi Model B and Desktop.

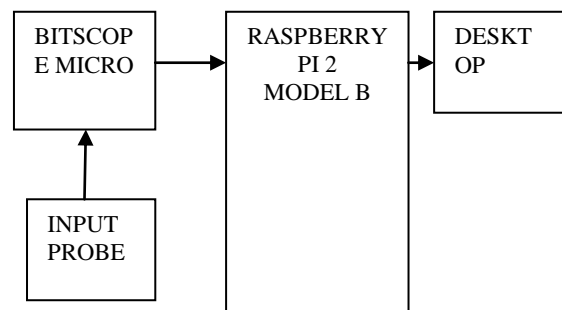

Fig 1 Block Diagram

1. Probe : To monitor analog signal the probe is designed, Analog signal of voltage up to $\pm 20V_{p-p}$ and frequency up to 1MHz.
2. Bit scope : After monitoring signal using probe, it is given to bit scope micro. This is the device having very high sampling rate and good resolution.

Using high speed ADC the analog signal has been converted to digital. This digital data is stored in memory of ARM Microcontroller so that the data should not loose. ARM support serial communication. Using serial communication data is given to USB port of Raspberry pi Processor for further processor. ADC used in this device is 12 Bit which gives resolution of 0.24mV. The device is having following specification.

20MHz bandwidth, 40MSps logic capture, 2 analog channels, 12 Bit native analog sample resolution, decodes serial , SPI, I2C, CAN and more, tiny, light weight and water resistant.

It is user programmable. program it in a variety of languages including C/C++, python or can integrate it with third party software.

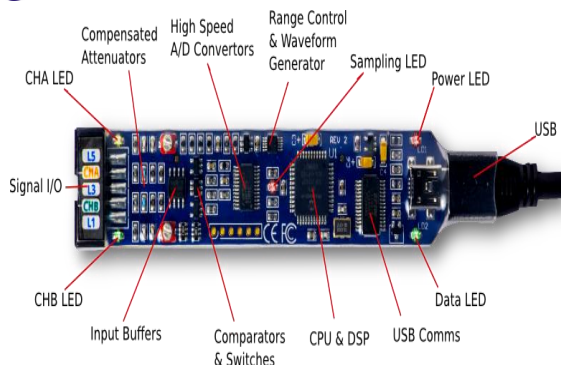

Fig. 2 Bit Scope

3. Raspberry Pi 2 Model B



Fig. 3 Raspberry pi 2

Microcontroller is the main part of the design. after the conversion of input analog signal the data is given on the USB port of the RPi. For USB access its programming is created in python. Graphical user interface is created and the data is displayed on the desktop. Using user interface waveform is shown on the desktop.

As like cathode ray tube the function have created, like voltage span, time span, waveform storage. channel selection of two channel. The RPi is having following specification. A 900MHz quad core cortex A7 CPU 1GB RAM, It also have 4 USB ports,40 GPIO pins, Full HDMI port, Ethernet port, Combined 3.5mm audio jack and composite video, Camera interface (CSI), Display interface (DSI), Micro SD card slot, Video Core IV 3D graphics core.

4. Desktop

Desktop is connected to raspberry pi on HDMI port and used for displaying graph of data. Also Raspberry pi is compatible with TFT display, which is touch screen.

5. Software

Python language is used for creating software. In software part USB data is accessed and first displayed it on console. After that this data is calibrated using Cathode Ray Tube. After calibration Graphical User Interface is created in Python scripting, which will plot the given data. For more clear view of data, zoom option is created for voltage and time. Also storage and reverse the waveform of data option is included. The GUI has become so much user friendly.

III. IMPLEMENTAION

As described in above description implementation of hardware is done. The system is 2 channels, so as shown in fig. 4. Two flexible probes has created, which are directly connected to Bit scope input. Bit scope output data is serial, which is given to Raspberry pi using data cable. The flow of system algorithm

1. Start
2. Detect input using Probe and give to Bit scope for ADC conversion.
3. Transfer converted data from Bit scope to USB port of Raspberry pi.
4. By making GUI in Python display the plot of data on Desktop.



Fig.4 System Implementation

IV. RESULTS

The system gives measurement of signal, its resolution and maximum values for different waveforms is as below,

1. Sine wave measurement results

TABLE I Voltage Measurement results

Sr. No.	Input Voltage(Vp-p)	Result Output(Vp-p)
1.	500m	450m
2.	1	970m
3.	3	2.80
4.	5	4.85
5.	10	10

TABLE II Freq. Measurement

Sr. No.	Freq. Input (Hz)	Freq. output (Hz)
1.	100	105
2.	500	510
3.	1K	1025
4.	10K	10.1K
5.	50K	50K

Resolution= 480mV

The maximum Voltage measurement = 10V

Frequency Resolution = 100Hz

Maximum Frequency measurement = 201 KHz

The sine wave signal from function generator of different voltages are given to the input of bit scope and checked its result is as shown below Fig. 5 and TABLE I.

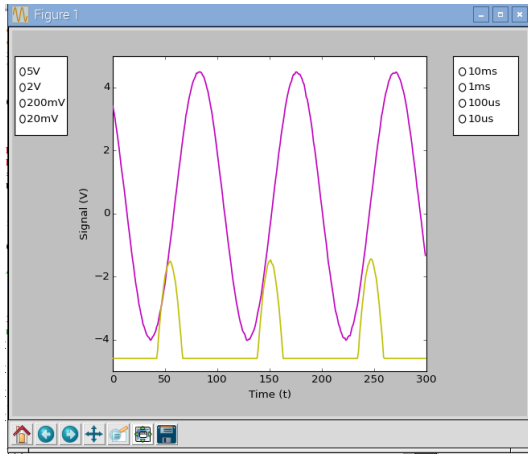

Fig. 5 Sine wave measurement

2. Square wave measurement results

Voltage Resolution= 50mV

The maximum Voltage measurement = 16V

TABLE II Voltage measurement

Sr. No.	Input Voltage(Vp-p)	Result Output(Vp-p)
1.	50m	50m
2.	500m	500m
3.	1	1
4.	5	5
5.	10	10

Frequency resolution = 150Hz

Maximum Frequency measurement = 602 KHz

TABLE III Freq. Measurement

Sr. No.	Freq. Input(Hz)	Freq. Output(Hz)
1.	150	150
2.	1K	1K
3.	10K	9.9K
4.	100K	99.8K
5.	400K	400K

The square wave signal from function generator of different voltage is given to the input of bit scope and checked its result is as shown below Fig. 6 and TABLE III.

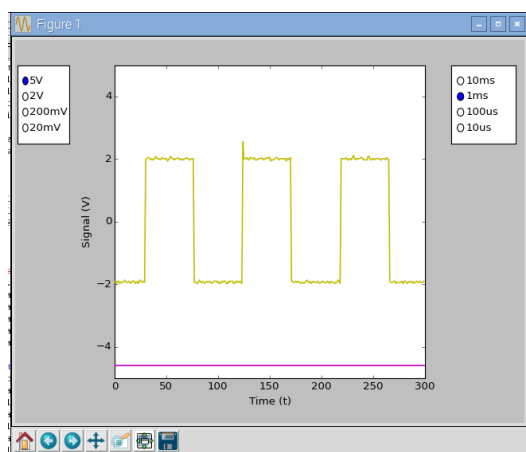

Fig. 6 Square wave measurement

II. CONCLUSION

This paper proposes the study of system which give ac and dc voltage and frequency measurement with good resolution and the range of voltage is $\pm 20V$ AC and range of frequency is up to 1MHz using Bit scope micro, Raspberry pi 2 processor, desktop and Programming of the algorithm and GUI is done in python.

ACKNOWLEDGMENT

This paper has been realized due to the guidance and support of many individuals, without whom, I would not have succeeded in implementing my ideas. I would like to take this opportunity to express my gratitude to them. I would like to thank **Dr. Mrs S. S. Lokhande** for the invaluable support and guidance that she has imparted. I am grateful to her for constant encouragement in fulfilment of paper. This work is result of combined efforts put in by my guide and me. I would also like to thank her for providing me with all necessary infrastructure and facilities to complete the review paper. I extend my special thanks to HOD of Electronics & Telecommunication Dr. M. B. Mali and all staff members.

REFERENCES

- [1] Raspberrypi.[Online].Available:<http://www.raspberrypi.org/>
- [2] History and Hardware [Online]. Available: http://en.wikipedia.org/wiki/Raspberry_Pi Ms. Sejal V. Gawande, Dr. Prashant R. Deshmukh, "Raspberrypi technology"
- [3] Kalyani ganavir, Hemant Waghmare, "Oscilloscope on Anndroid phone", Volume 3, Issue 4ISSN: 2277 128X, 2013.
- [4] A Raspberrypi Technology [Online]. Available: <http://www.collegelib.com/t-raspberrypi-technologyintro-pecifications-seminar-abstract-technicalreport.html>