

Design, Fabrication and Performance Analysis of Solar Tunnel Dryer Using Various Absorber Materials

Piyush S. Thakre¹, Prof. S.S. Deshmukh², Pratik Jain³

M. Tech Scholar, Dept of Mechanical Engineering, Ramdeobaba College of Engineering Nagpur, Maharashtra, India^{1,3}

Asst Professor, Dept of Mechanical Engineering, Ramdeobaba College of Engineering Nagpur, Maharashtra, India²

Abstract: Sun drying of agricultural products is the traditional method employed in most of the developing countries. Sun drying is used to denote the exposure of a commodity to direct solar radiation and the convective power of the natural wind. Drying is cheapest and most common method of preservation and storing of agricultural products. It was observed that dryer efficiency continuously changing during drying process due to change in solar radiation and temperature. Performance of solar tunnel dryer is depends upon on different performing parameters. The flow rate, temperature and relative humidity of drying air plays major role in drying. Also moisture content in product, area of collector plate, thickness of polythene sheet, absorbing material and thickness of drying layer are important parameter. The main aim of this project is do the performance evaluation of solar tunnel dryer by varying input performing parameters such as absorber material for collector area flow rate of drying air and thickness of polythene sheet and to determine the output performance parameters such as efficiency of solar tunnel dryer, Time required for drying agricultural product, and cost of solar tunnel dryer.

Keyword: Solar tunnel dryer, Performance parameter, Absorber material, OSD (Open Sun Drying).

I. INTRODUCTION

Agriculture is the main source of livelihood in India. The solar energy option has been identified as one of the promising alternative energy sources for the future. Drying is one of the essential unit operations performed to increase the shelf life of agricultural product and it is one of the most practical methods of preserving food and the quality of the agricultural product. If the drying process is not completed fast enough, growth of micro-organisms will take place as a result of the high relative humidity. This often leads to severe deterioration of the quality of the product. Traditionally, the food products are dried by spreading in open sun in thin layer. Though this method is economical and simple, it has the drawbacks like; no control over the rate of drying, non-uniform drying, chances of deterioration due to exposure of products against rain, dust, storm, birds, rodents, insects and pests which results in poor quality of dried products.

A. Solar Tunnel Dryer

Several types of solar dryers have been developed and used to dry a variety of agricultural product. Solar tunnel dryer is widely used for drying various agricultural product. The solar tunnel dryer consists of different parts such as drying chamber, collector area and chimney. A solar tunnel dryer is a tunnel like framed structural covered with Ultra-violet (UV) stabilized polythene sheet, where agricultural and Industrial products could be dried under drying chamber. The product is to be dried are placed in the tunnel dryer. A thermocol is used as an insulation material to reduce heat loss from the dryer. The air at the required flow rate is provided by a DC operated

fan by a battery. To prevent the entry of water inside the dryer unit when it rains, the cover is fixed like a sloping rod or semi cylindrical shape. Solar radiation (SR) passed through the transparent cover of the collector. Heat is transferred from absorber to the air in the collector and heated air from the collector passed over and absorbed moisture from the products. SR also passed through the transparent cover of the dryer and heated the products in the dryer.

Solar Tunnel Dryer is majorly depends on weather conditions to get better output the day should be clear sunny day so we can get maximum beam radiation incident on dryer. Solar tunnel dryer is very much useful for small scale farmers and household farmers for drying agricultural product which can be prevented from deterioration from rain, dust and insects by cover material There are various performing parameters of solar tunnel dryer which affect the performance of solar dryer such as absorber material of collector, covering polythene sheet thickness, air flow velocity, drying layer thickness relative humidity of air. So it necessary to evaluate the performance of solar tunnel dryer by considering those parameters to get better output parameters such as cost of efficiency of dryer and total time required for product drying.

B. Working of Solar Tunnel Dryer

A solar tunnel dryer is a tunnel like framed structural covered with Ultra-violet (UV) stabilized polythene sheet, where agricultural and Industrial products could be dried

under drying chamber. The product is to be dried are place inathin layer in the tunnel dryer. A thermocol is used as an insulation material to reduce heat loss from the dryer. The air at the required flow rate is provided by a DC operated fan by a battery. Solar radiation (SR) passed through the transparent cover of the collector. Heat is transferred from absorber to the air in the collector and heated air from the

collector passed over and absorbed moisture from the products. SR also passed through the transparent cover of the dryer and heated the products in the dryer. Sun is the major source of all types of energy sources. Solar energy is an elaboration of sun energy in efficient way with the help of solar tunnel Dryer.

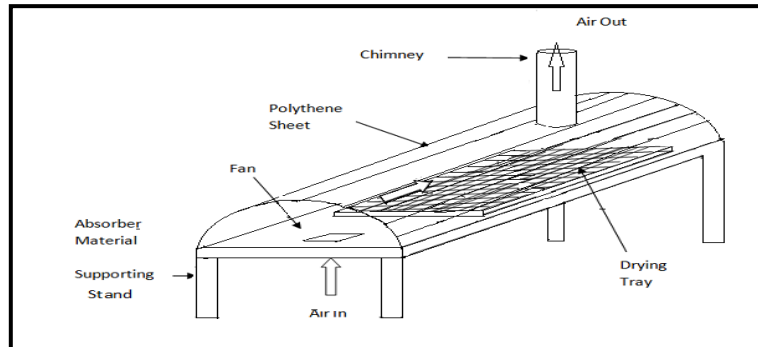

Figure I Schematic of Solar Tunnel Dryer

II. FINAL DESIGN OF TUNNEL DRYER

- Width (b) of solar tunnel dryer as 2 feet or 0.6096 m
- Length (l) of solar tunnel dryer as 4.053 ft or 1.23 m
- Radius or height of semicircular ring of solar tunnel dryer = 0.3048m

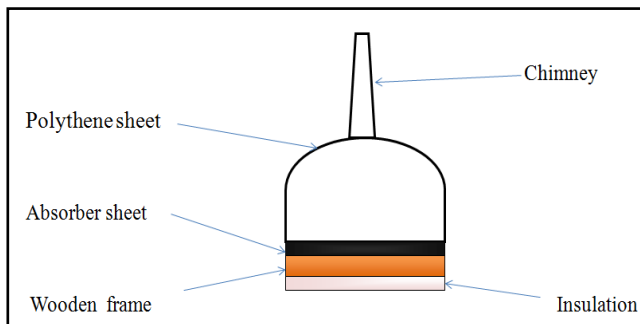

Figure II Side View of Dryer

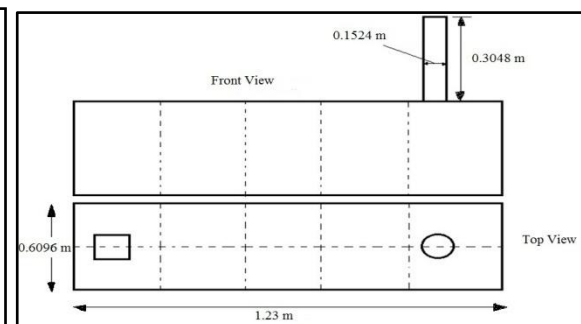

Figure III Front View and Top View of Dryer

III. DRYING PRODUCT (CHILI)

India is not only the largest producer but also the largest consumer of chilly in the world. Chilies are the most common spice cultivated in India.

Chilly is a universal spice of India. It is cultivated in all the States and Union Territories of the country. India contributes about 36% to the total world production.



Figure IV Chili Plant

In India, Chilies are grown in almost all the state throughout the country. Andhra Pradesh is the largest producer of Chilly in India and contributes about 26% to the total area under Chilly, followed by Maharashtra

(15%), Karnataka (11%), Orissa (11%), Madhya Pradesh (7%) and other states contributing nearly 22% to the total area under Chilies.

IV. DESIGN OF EXPERIMENT

As per identified performance parameter of solar tunnel dryer four input parameter are consider for design of experiment such as absorber material for dryer with different coating materials, thickness of drying layer, thickness of covering sheet and flow velocity of air. These input parameter are taken to determine the effect of those parameter on efficiency and drying time of dryer. Aluminum sheet is taken as a base absorber material, on which the coating material (black paint, graphite powder, copper powder) were used to increase absorptivity of aluminum. 130 micron semitransparent polythene sheet is used for covering. 20 mm drying layer were use for chili drying. The size of single chili is 20 mm. flowing air velocity 0.4 m/s were used for drying.

Table I Design of Experiment

Sr. No	Absorber Material (Coating)	Covering Sheet thickness (micron)	Flow velocity (m/s)	Drying layer thickness (mm)
Set – 1	Aluminium	130	0.4	20
Set – 2	Black Paint as Coating Material	130	0.4	20
Set – 3	Black Paint + Graphite Powder as coating material	130	0.4	20
Set – 4	Black Paint + Copper Powder as coating material	130	0.4	20
Set – 5	Open Sun Drying (OSD)	130	–	20

Table II Properties of Absorber (Coating) Material

Absorber Material	Absorptivity	Availability
Aluminum	0.15	Easy
Black paint	0.98	Easy
Graphite Powder	0.64	Easy
Copper Powder	0.84	Easy



Figure V Experimental Setup

V. DATA ANALYSIS

A. Temperature Variation in Dryer for Set-1 (Aluminium as a absorber)

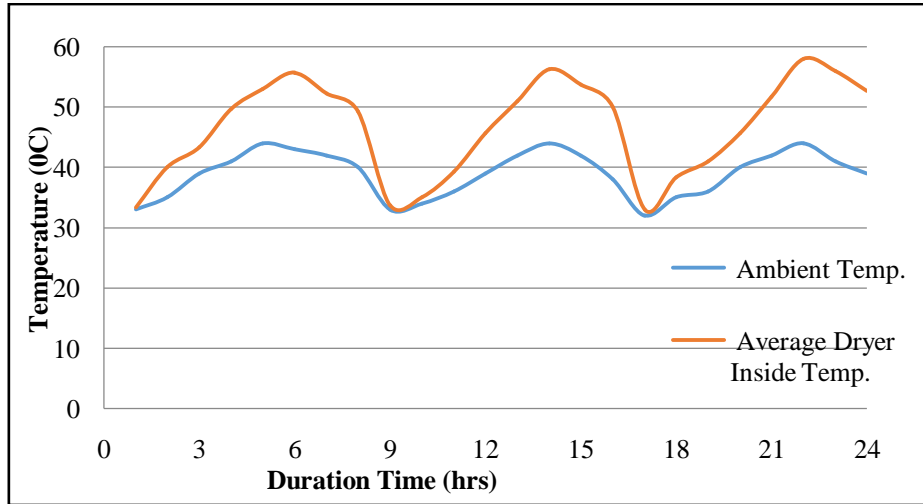

Figure VI Graph showing Duration (Drying) Time vs Temperature

B. Temperature Variation in Dryer for Set-2 (Absorber Coated with Black Pain)

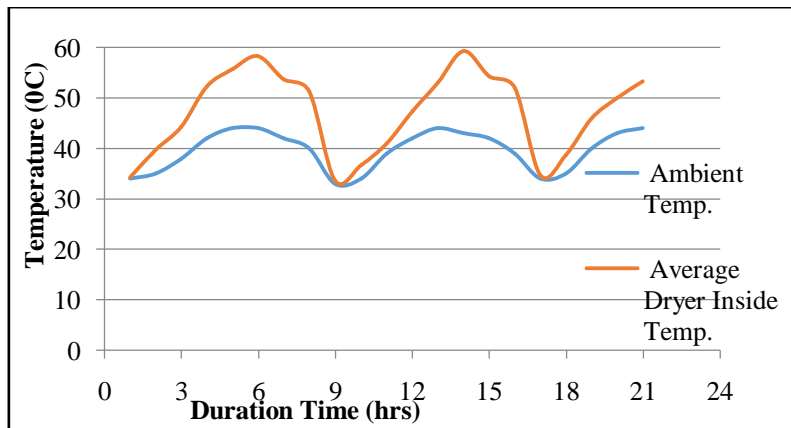

Figure VII Graph showing Duration (Drying) Time vs Temperature

C. Temperature Variation in Dryer for Set-3 (Absorber Coated with Black Pain and Graphite Powder)

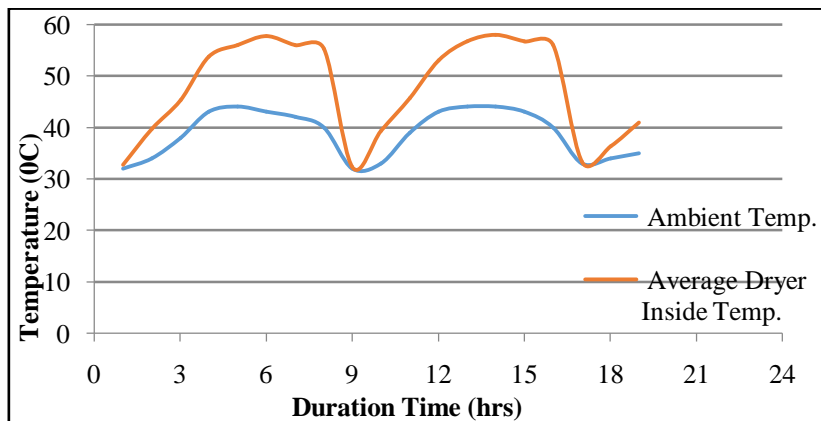

Figure VIII Graph showing Duration (Drying) Time vs Temperature

D. Temperature Variation in Dryer for Set-4 (Absorber Coated with Black Paint and Copper Powder)

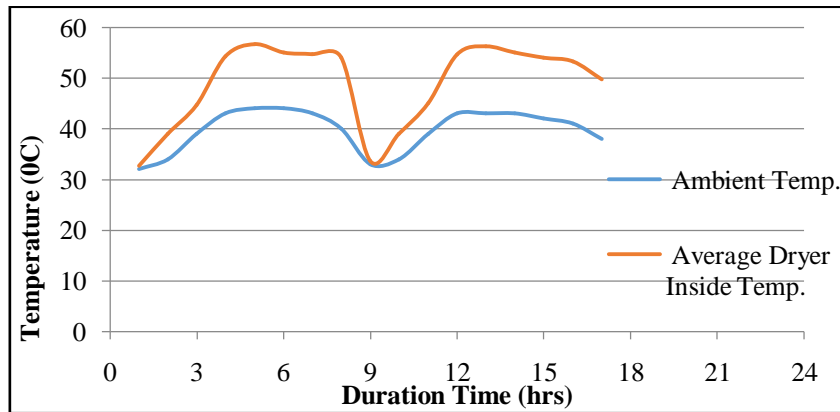

Figure IX Graph showing Duration (Drying) Time vs Temperature

E. Temperature Variation in Dryers with OSD

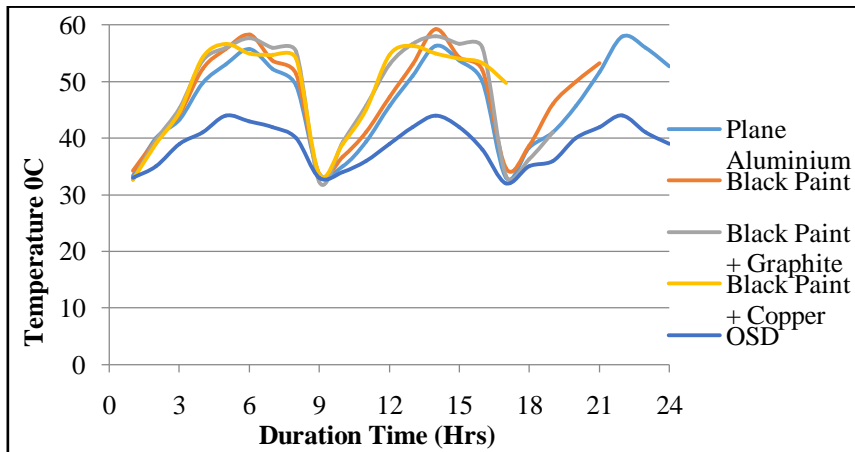

Figure X Graph showing Duration (Drying) Time vs Temperature

In all above figures it was observed that the temperature difference is high due high solar radiation intensity. 10 to 16 °C higher temperatures obtain inside the morning as compare to evening and afternoon period, dryer as compared to open sun drying (ambient higher in the afternoon period. In the afternoon the temperature).

F. Efficiency of Dryers (Drying Days vs Efficiency)

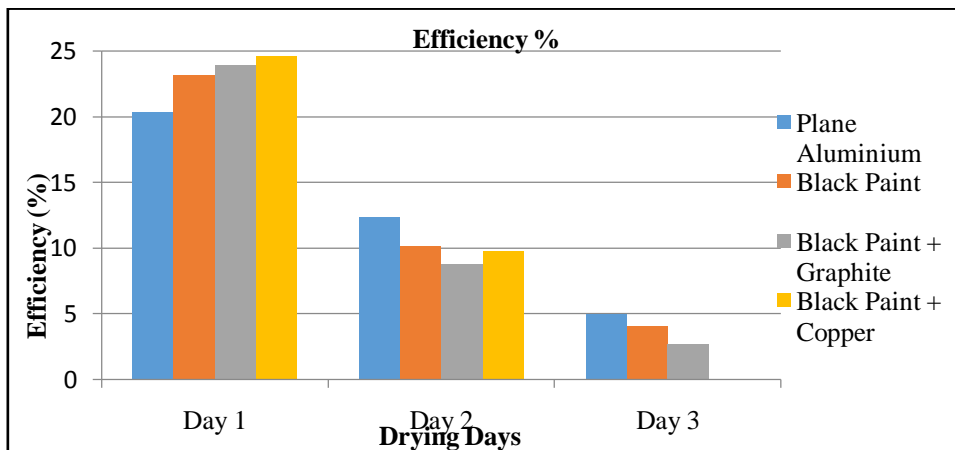

Figure XI Graph showing per Day efficiency of Solar Tunnel Dryer

G. % Moisture Removal for Dryer

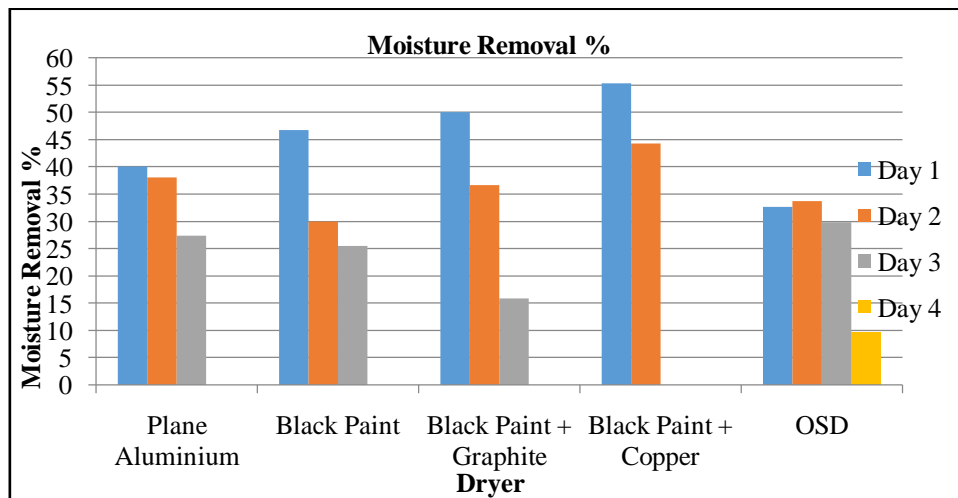

Figure XII Graph showing Per Day Moisture Removal

H. Drying hours of Dryer

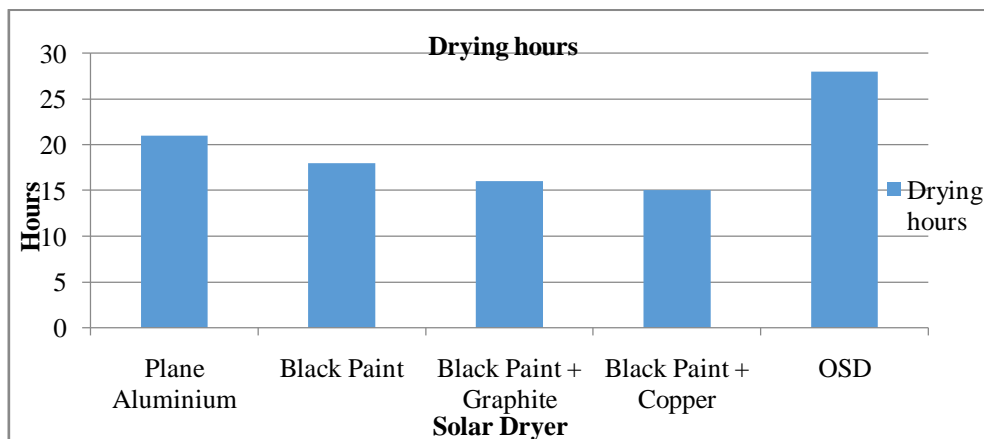

Figure XIII Graph showing Variation in Drying hours for Dryer

CONCLUSION

In the Present study, the thermal performance of solar tunnel dryer based was studied. The solar tunnel dryer was used to drying the chili as a drying product for experimentation. Experimental investigation has been carried out on three types of Selective coating material viz. Black paint, graphite powder, and Copper powder. Following conclusions can be drawn from the experimentations:

- The drying time considerably reduced by using solar tunnel dryer and quality of final product is good. The temperature difference between inside and outside of dryer was low in the morning and evening periods as compared to afternoon.
- In can be observed that the use of copper powder as a coating material on the absorber the dryer efficiency is maximum, which is higher than the other coating material as tested in the present system.
- Maximum efficiency of collector is achieved by 24.6 % with copper powder as coating material to the absorber.
- The percentage change in drying time is reduces considerably by 46.64% with copper powder as a coating material as compare to the Open Sun drying.
- The percentage change in moisture removal rate is 64.24% as compared to the open sun drying.
- In second day, the removal of the moisture content in chili is less hence, efficiency of the dryer is less.
- The present system is cost effective as compared to the dryer available in market.

REFERENCES

[1] M.A. Hossain ,B.K.Bala, “ Drying of hot chilli using solar tunnel dryer,” Solar Energy,81,pp.85-92.
[2] Biplab Paul, S P Singh, “ A review of solar dryers design & developed for chilli ,” International journal of Research in Advent technology.2013 vol.1.

- [3] AnjumMunir, Umair Sultan and Muhmmad Iqbal, “ Development and performance evaluation of locally fabricated portable solar tunnel dryer for drying of fruits, vegetables and medicinal plants,” pak.J.Agri. Sci. Vol 50(3);2013.
- [4] M.S. Seveda , “Design and development of walk-in type hemicylindrical solar tunnel dryer for industrial use ” International Scholarly Research Network Renewable Energy , 2012, V. 12 , Article ID 890820 j
- [5] Satish R. Desai,V.Vijaykumar, and Anatachar M., “ Performance evaluation of farm solar dryer for chilli drying,” Karnataka Journal of Agricultural Science, 2009 Vol. No. 22.
- [6] SeremJanjai, “ A greenhouse type solar dryer for dried food industries: Devalopement and dissemination,” International Journal Of Energy and Environment, 2012, Vol. 3.
- [7] S.Janjai, N.Sristtipokakun ,B.K.Bala , “Experimental and simulated performance of roof integrated solar drier for drying herba and spices”Food science and technology research,2008, Energy 33.
- [8] M. S. Dulawat, and N. S. Rathore, “Forced convection type solar tunnel dryer for industrial applications,” AgricEngInt: CIGR Journal, 2012.
- [9] B.M.A. Amer, M.A. Hossain, K. Gottschalk, “Design and performance evaluation of a new hybrid solar dryer for banana,” Energy Conversion and Management, 2010, 51.
- [10] TalivHussain ,Sarvasindhu Mishra, Anugrah Soy, “ An application of solar dryer in order to removed moisture and differntiating with sample dried in opean air,” IJARSE, 2015, Vol.4.
- [11] Dr. Sivaraj Kumar, James Williams, Prof.P.Karthikeyan, “An overview of optimization techniques use in solar drying,” AJSAT , 2013, Vol.1
- [12] GarimaTiwaria, KatiyaV. K., VivekDwivedia, Katiyarb A. K. and Pandeyb C. K., “A Comparative study of commonly used Solar Dryers in India” International Journal of Current Engineering and Technology ,2013, Vol 3.
- [13] Hatem Oueslati, Salah Ben MabroukAbdelkaderMami, “Design and Installation of a Solar-Gas Tunnel Dryer” The fifth International Renewable Energy Congress IREC, 2014.
- [14] S Ayyappan , K Mayilsamy, “Experimental investigation on a solar tunnel dryer for copra drying,” Journal of Scientific & Industrial Research, 2010 V. 69.
- [15] J. E. Berinyuy , J. K. Tangka, G. M. Weka Fotso, “Enhancing natural convection solar drying of high moisture vegetables with heat storage,” AgricEngInt: CIGR Journal, 2012, Vol. 14.
- [16] Sevda M.S. and Rathore N.S. 2007 “Studies on Semi-Cylindrical Solar Tunnel Dryer for Drying Di-basic Calcium Phosphate” Agricultural Engineering International: the CIGR Ejournal.,2007.
- [17] M. Mohanraj , P. Chandrasekar , “ Performance of a force convection solar drier integrated with gravel as heat storage material for chilli drying ,” Journal of Engineering Science and Technology ,2009, Vol. 4.
- [18] Abhishek Saxena ,Ghanshyam Srivastava, “Performance studies of a multipurpose solar energy system for remote areas,” International Journal of Mechanical Engineering ,2013, Vol. 3 No. 1.
- [19] Navin Chandra Shahi ,Umesh C. Lohani , Anupama Singh , Anil Kumar, “ Development of polyhouse type solar dryer for Kashmir valley,” Journal of Food Science technology, 2011, Vol. 48(3).
- [20] B.R. Chavan, A.Yakupitiyage, S. Kumar, “Drying performance, quality characteristics and financial evaluation of Indian mackerel (rastrilligerkangurta) dried by a solar tunnel dryer,” Thammasat Int. J. Sc. Tech., 2011, Vol. 16, No. 2.
- [21] B.K.Bala, M.A. Morshed, M.F. Rahman, “ Solar drying of mushroom using solar tunnel dryer,” International Solar Food processing Conference, 2009.
- [22] Benjamin TernengeAbur ,Habou Dan-Dakouta, Gerry Egbo, “ Food security : Solar dryers and effective food preservation,” International Journal of Advanced Research and Studies, 2014, Vol. 3.
- [23] L.Kagande, S. Musoni, J. Madzore, “Design and performance evaluation of solar tunnel dryer for tomato fruit drying in Zimbabwe,” IOSR Journal of Engineering, 2012, Vol. 2.
- [24] S Ayyappan, K Mayilsamy, “Experimental investigation on solar tunnel drier for copra drying,” Journal of Scientific and Industrial Research,2010, Vol. 69.
- [25] Rahul Wandra, Anurag Soy, Taliv Hussain, “Application and effectiveness of low cost solar cabinet dryer: Experimental investigation,” IOSR Journal of Mechanical and Civil engineering, 2013