

# Intelligent Environment: A ECSN Smart Home Technology

Sachin Sonawane<sup>1</sup>, P. B. Borole<sup>2</sup>, Mayur Kadlag<sup>3</sup>

M.Tech Student, Electrical Department, VJTI Matunga, Mumbai, India<sup>1,3</sup>

Associate Professor, Electrical Department, VJTI Matunga, Mumbai, India<sup>2</sup>

**Abstract:** Intelligent Environments mark out physical environments in which sensor networks are used to assemble information of the surroundings in which we live. Which deals with the design and implementation of environment sensing system based on Arduino and ZigBee using embedded controlled sensor network (ECSN). Sensor networks are compact wireless networks of small, low-cost sensors, which collect and spreads environmental data. So called intelligent environment as it helps inhabitants to automate task components. They have applications in a variety of fields such as environmental monitoring, military purposes and gathering sensing information in inhospitable locations. In the proposed system Arduino based controller and wireless sensors are used to control various parameters of home and are networked to monitor the information regarding the home environment using ZigBee and Visual Basic06. Using Visual Basic06 the various parameters are displayed on GUI panel and also parameters versus time graph is plotted. This paper presents an idea of low cost and less power consuming smart home system. This system is flexible and controlled by user friendly Embedded System. Purpose of system to enhance ordinary life and automate non living things.

**Keywords:** Intelligent Environments, ZigBee, Arduino, Visual Basic06, ECSN.

## I. INTRODUCTION

Environment monitoring and device control allows new level of comfort in homes and it can also manage the energy consumption efficiently which in turns promotes the saving. Remote controlling of the devices offers many advantages to senior citizens and people with disabilities which helps them in being more autonomous and increasing quality of life.

Embedded controlled sensor networks (ECSN) are mainly designed to be application- specific so that the energy consumption is minimum as the battery-powered nodes demand life-time of several months or even a few years[1].

The goal of the project is to create Home automation or smart homes (also known as domotic) can be described as introduction of technology within the home environment to provide convenience, comfort, security and energy efficiency to its occupants[2]. Automation and network of busy families and individuals will be physical Limitations. IBOARD is Ethernet Shield, and it was the smart Home micro web server. Arduino open source electronics prototyping platform based on Flexible, easy-to-use hardware and software.

The Arduino IBOARD Microcontroller Board of Based on the IBOARD with 54 digital input / output pins. The Ethernet interface is Arduino Arduino via the SPI pins. Low- voltage switching relays were used to integrate Devices with Arduino is to show switching functionality. The LM35 temperature Sensor is used to control a smart home environment[3].

There is a severe need to monitor temperature or gases as they can be costly and deadly. A monitored low temperature sensor warns about freezing temperatures inside house. Also if the boiler, washer or pipes leaks in the home, it can cause considerable damage. Guangming Song (etc) developed a wireless-controllable power outlet system. Researchers have worked on home automation and environmental monitoring system in the past but in the existing systems cost is high, size is an issue and they are difficult to maintain[4]. Combined wireless ZigBee communication technology with data acquisition system builds wireless sensor network system based on ARDUINO processor and ZigBee chip. This system many important advantages such as low cost, low power Consumption, and low data rate.

The system is simpler, integrated, anti-interference, stronger mobility and practicability. The overall system will consist of a Sensor node comprises different sensors, Arduino controller, LCD display, ZigBee, GUI(Visual Basic06)and relay driven indicators at the end user. The plan is to construct a product that is portable, easy to use, efficient, and inexpensive.

## II. LITERATURE SURVEY

In the twenty first century, there is revolution of the sensor networks which have also come up with various applications like surveillance, traffic control, environmental and wildlife monitoring, agricultural application, home automation and industrial process control [1]. Home automation system has been around for more than a decade.

The main concept is to form a network connecting the electrical and electronic appliances in a house. This is a growing technology, which has changed the way people live. According to the data published by the market research and market intelligence firm ABI about 4 million home automation systems were sold globally in 2013. It is also estimated by the same organization that 90 million homes worldwide will employ home automation systems by the end of 2017.

There have been several commercial and research versions of smart home system introduced and built. But, none of the versions has broken through the mainstream yet other than security systems. Smart home systems have captured many disparate technologies so far and products have been in the market for more than one decade. Many companies have entered in this field including Google. Google has announced an ambitious project named Android@Home for smart home platforms[5].

The world has become a global village due to revolution in the technology; in this revolution the IT (information technology) played an important role. Similarly the revolution in IT makes mankind dream come true to have an automated home. Home automation use microprocessor-based intelligence to integrate or control electronic products and systems in the home. The incentive behind home automation is efficient utilization of electricity. So a variety of research and many solutions had proposed on home automation. These systems use PC, mobile internet, GSM Bluetooth and ZigBee network etc[6].

Intelligent environments are often cited as a promising solution for enabling elderly people an independent life in a familiar surroundings. Based on the initial idea of ubiquitous computing, the concept of intelligent environments envisions a future, where a multitude of computers are seamlessly embedded into everyday objects of the physical world[7].

The available technologies are Bluetooth, Wi-Fi, Wi-Max, wireless mobile Ad-hoc network (WMANET), UWB, wireless HART, Bluetooth and ZigBee. Embedded sensor networks are formed by communicating over wireless links without using a fixed networked infrastructure controlled by microcontroller. ZigBee is the name for a short-range, low-power, low-cost, and low-data-rate wireless multi-hop networking technology[8]. Generally, home automation research targeted many needs; some applications fulfil the sophisticated and luxury requirements.

### III. PROPOSED BLOCK DIAGRAM

#### A. Sensors

A sensor is a device that detects and responds to some type of input from the physical environment. The input can be light, heat, motion, moisture, pressure, or any one of a great number of other environmental phenomena. The output is generally a signal that is converted to human-

readable display at the sensor location or transmitted electronically over a network for reading or further processing.

1) Temperature sensor (LM35): Temperature monitor and control node work according to the temperature value defined, first it get the values from sensor and displayed on LCD. The LM35 is commonly used sensor which has range of  $-55^{\circ}$  to  $-150^{\circ}\text{C}$ . The LM35 series are precision integrated-circuit LM35 temperature sensors, whose output voltage is linearly proportional to the Celsius (Centigrade) temperature. The LM35 sensor thus has an advantage over linear temperature sensors calibrated in  $^{\circ}$  Kelvin, as the user is not required to subtract a large constant voltage from its output to obtain convenient Centigrade scaling[8].

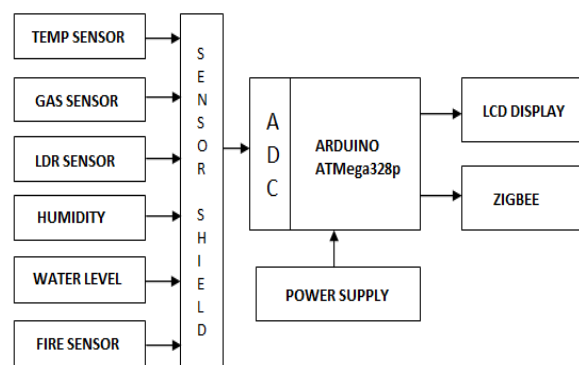

Fig. 1. Block diagram of Tx

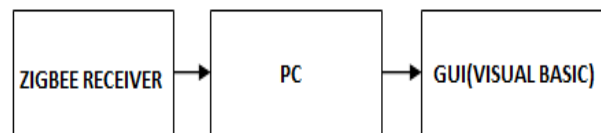

Fig. 2. Block diagram of Rx

2) Humidity Sensor: The humidity level monitoring system monitors and the current humidity level and maintain it around a predefined value. When the system detects a drop in humidity level then turn on motor pump allowing water to flow to ground. To measure humidity, amount of water molecules dissolved in the air of environments, a smart humidity sensor module SY-HS-220 is opted for the system under design..The humidity sensor used in this system is highly precise and reliable. It provides DC voltage depending upon humidity of the surrounding in RH%. This work with +5 Volt power supply and the typical current consumption is less than 3mA. The operating humidity range is 30% RH to 90% RH. [8].

3) Light Dependant Resistor: A light dependant resistor also know as a LDR, photo resistor, photoconductor or photocell, is a resistor whose resistance increases or decreases depending on the amount of light intensity. A LDRs can have a variety of resistance and functions. For example it can be used to turn on a light when the LDR is in darkness or to turn on a light when the LDR is in light. It can also work the other way around so when the LDR is in

light it turns on the circuit and when it's in darkness the resistance increase and disrupts the circuit[9].

4) Gas Sensor: Gas sensor we are using is MQ-6. Sensitive material of MQ-6 gas sensor is SnO<sub>2</sub>, which with lower conductivity in clean air. When the target combustible gas exist, the sensors conductivity is higher along with the gas concentration rising. Convert change of conductivity to correspond output signal of gas concentration[8]. Gas sensor is an analog sensor and gives the output into form of analog signal. This signal is feed to ADC which will convert it into digital form. Once converted into analog form, the microcontroller can process the digital gas signal as per the application[9].

5) Flame detector : It is a sensor designed to detect and respond to the presence of a flame or fire. Responses to a detected flame depend on the installation, but can include sounding an alarm, deactivating a fuel line (such as a propane or a natural gas line), and activating a fire suppression system. A flame detector can often respond faster and more accurately than a smoke or heat detector due to the mechanisms it uses to detect the flame.[10]

6) Water level indicator: The sensing probe element consists of a special wire cable which is capable of accurately sensing the surface level of nearly any fluid, including water, salt water, and oils. The sensor element is electrically insulated and isolated from the liquid into which it is inserted, and will not corrode over time. Unlike, other sensors, the measurement range is adjustable from a few centimetres to over several meters. The reading is reported back as an analog voltage ranging from 0V to 3V where 0V represents the sensor not being submersed, and 3V represents the maximum water level.[10].

#### B. Controller Unit(ATMega328P)

The Atmel ATmega328P is a low cost, mid-range performance microcontroller. It features a 20 MHz clock, 32 KB flash memory for programming, 2 KB SRAM, and 1 KB of non-volatile EEPROM.

The chip runs at 5V DC and contains 14 general digital input/output pins, of which 6 can be used for PWM outputs, and 6 analog input pins. The microcontroller contains one hardware USART serial port, Serial Peripheral Interface Bus (SPI) and Two- Wire Interface (TWI) communication.

This microcontroller can be programmed using Atmels AVR Studio software. The Integrated Development Environment (IDE) allows programming in either C/C++ or assembly code.

#### C. ZigBee Module

For transmission purpose, ZigBee module is used in the system at sensor Node. It works in unlicensed ISM frequency band of 2.4GHz. ZigBee module uses standards protocol (defined as IEEE 802.15.4). Open source X-CTU software is used to configure this module.

The RF Module can be configured as Coordinator, End

Device or Router, using XCTU software. In system, ZigBee typically uses baud rate of 9600 which is set by XCTU. It operates on input power supply of 3.3V. Input pin voltage at ZigBee RF module should not exceed 3.3 volts.

#### D. Relay Circuit

A relay is an electrically operated switch. Relays are used where it is necessary to control a circuit by a low-power signal (with complete electrical isolation between control and controlled circuits), or where several circuits must be controlled by one signal.

In our system the output from Arduino is directly given to relay circuit. According to the output of Arduino, corresponding relay will turn on and makes its device working. We are using a NPN transistor in relay and it works on the concept of EMF.

#### E. VISUAL Basic(GUI)

It is a VISUAL and events driven Programming Language. These are the main divergence from the old BASIC. In BASIC, programming is done in a text-only environment and the program is executed sequentially.

In VISUAL BASIC, programming is done in a graphical environment. Because users may click on a certain object randomly, so each object has to be programmed independently. To be able to response to those actions (events). Therefore, a VISUAL BASIC Program is made up of many subprograms, each has its own program codes, and each can be executed independently and at the same time each can be linked together in one way or another.

### IV. SOFTWARE AND HARDWARE APPROACH

Physical Parameters of the environment are sensed by data acquisition system using sensors. At sensor node six different sensors listed temperature sensor, water level indicator, Gas sensor, humidity sensor, LDR sensor are interfaced with an Arduino using sensor shield. Sensor shield simply connects the Arduino pins to many connectors that are ready to connect various devices with simple cables.

Depending on the output (Analog/Digital) of the sensors, the gathered data is digitized using inbuilt ADC of the Arduino. The threshold is set by control unit is compared with the output of the sensors. The output from Arduino is given to the relays to turn ON/OFF indicators like LEDs, Fan, Buzzer etc. Digitized data from the Arduino is transferred by serial communication through ZigBee module. ZigBee is a two way communication protocol.

At receiver end the data is received using ZigBee module and data is displayed using VISUAL Basic GUI. In VISUAL Basic the graphs of different parameters against time is viewed. Also the excel sheet is generated for data base. The output of the controller is displayed on the 16x4 LCD for example Room temperate, CO percentage, Humidity, Light Intensity, Fire status etc.

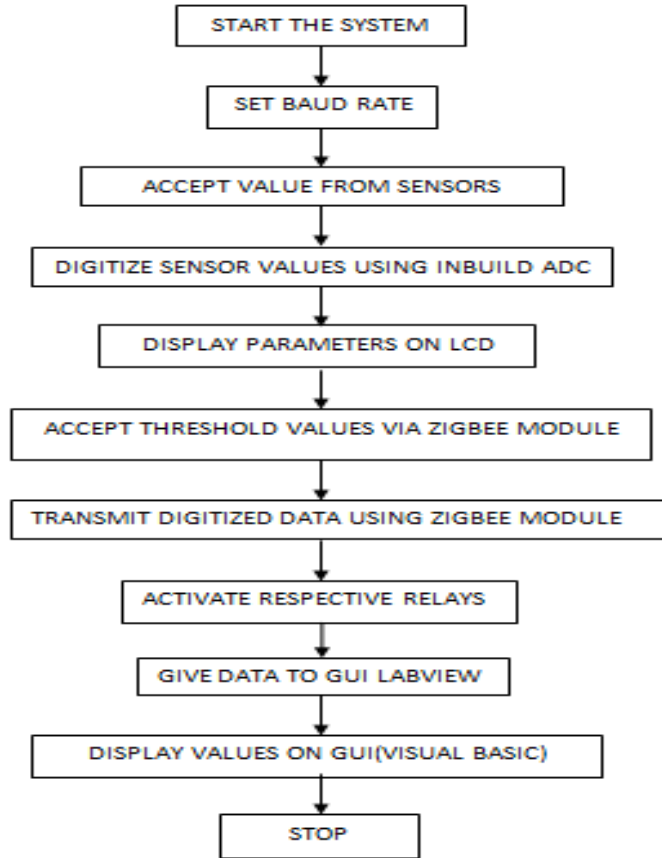
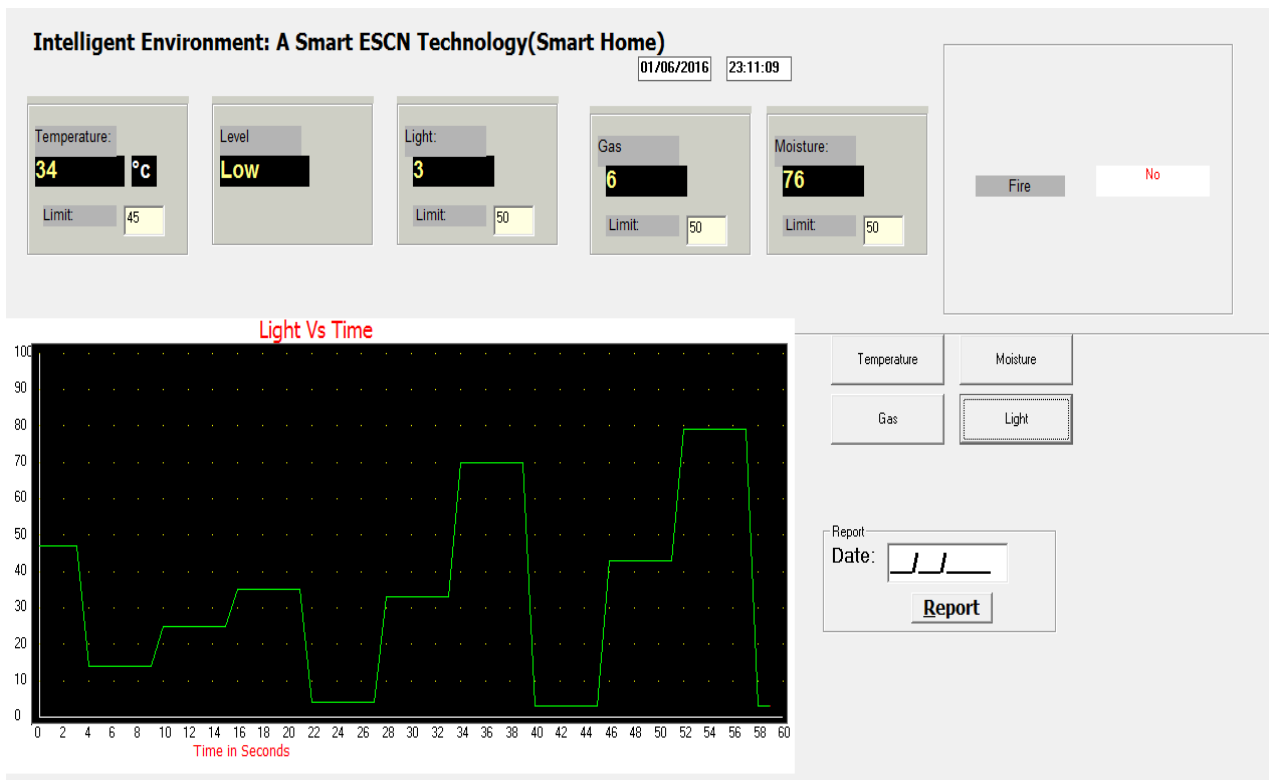

Fig. 3. Flow diagram of the system

V. RESULTS OF SYSTEM

All environmental parameters are read through sensors and displayed on LCD. Results are shown below.



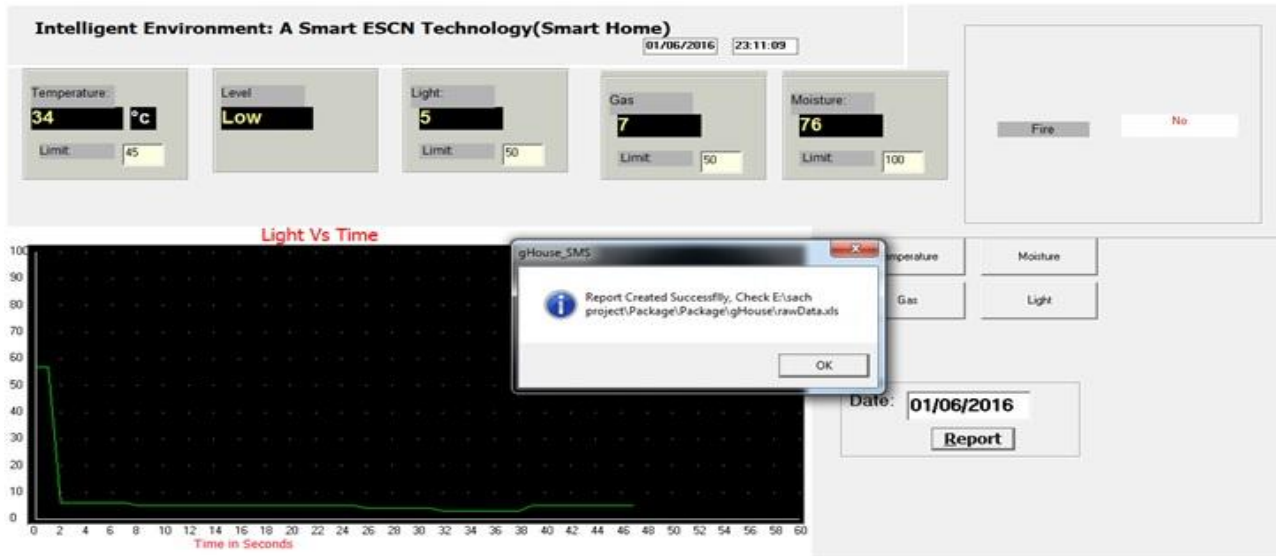

Fig. 4. Snapshots of GUI of the system

## VI. CONCLUSION

System is designed and works as expected. Sensor networks is designed for controlling the home devices as well as monitoring the environmental parameters like temperature, light percentage, LPG Percentage, humidity, fire detection and water level indication.. The output of sensors is digitalized and transmitted over wireless communication at Sensor unit and respective relays are activated. At Control unit, current data is displayed on Visual Basic GUI with different graph display and also parameters output is saved in excel sheet. The features of Arduino and ZigBee are explored to design the system for long distance as well as short distance. Embedded controlled sensor networks have proven themselves to be a genuine solution in providing remote control and sensing for indoor environmental monitoring systems.

- [7] Carsten Rocker, "Intelligent Environments as a Promising Solution for Addressing Current Demographic Changes," Human-Computer Interaction Center (HCIC) of RWTH Aachen University, Theaterplatz 14, 52056 Aachen, Germany.
- [8] Shrikant M.B, Basavanagouda G, "Design And Implementation Of Environment Sensing System Based On GSM/GPRS Using Embedded Controlled Sensor Network," International Journal of Combined Research & Development (IJCRD ) pg35,Volume: 2; Issue: 5; May -2014.
- [9] [en.wikipedia.org/wiki/sensors](http://en.wikipedia.org/wiki/sensors)
- [10] [www.hwsensors.com](http://www.hwsensors.com)

## REFERENCES

- [1] Vaneet Singh, I. P. Singh, S. K. Sud, "Environment monitoring and device control using ARM based Embedded Controlled Sensor Network," IEEE Transactions on Automation, 978-1-4673-5301-4/13/\$31.00 ©2013.
- [2] Rajeev Piyare, Seong Ro Lee, "Smart Home-Control and Monitoring System Using Smart Phone," Proceedings, The 1st International Conference on Convergence and it's Application. ICCA 2013, ASTL Vol. 24, pp. 83 - 86, 2013 © SERSC 2013.
- [3] Zaid Abdulzahra Jabbar, R.S. Kawitkar, "Implementation of Smart Home Control by Using Low Cost Arduino & Android Design," International Journal of Advanced Research in Computer and Communication Engineering Vol. 5, Issue 2, February 2016.
- [4] Mohd Imran, Hilal Ahmad Malik, "Implementation of Environment Monitoring and Device Control using ARM Based Embedded Control Sensor Network," Proceedings of the 8th International Conference, Guanajuato Mexico, IEEE Press; 2012.
- [5] Thoraya Obaid, Haliemah Rashed, Ali Abu El Nour, "ZigBee based Voice Controlled Wireless Smart Home System" International Journal of Wireless & Mobile Networks (IJWMN) Vol. 6, No. 1, February 2014.
- [6] Faisal Baig, Saira Beg, Muhammad Fahad Khan, "ZigBee Based Home Appliances Controlling Through Spoken Commands Using Handheld Devices." International Journal of Smart Home Vol. 7, No. 1, January, 2013.