

Overview of Thermal Power Plant

Tarun Kumar

Department of Electrical & Instrumentation, Thapar University, Patiala, Punjab

Abstract: Thermal Power Plant is a major source of electricity production by coal. We will understand the overview of Thermal Power Plant i.e its parts such as boiler, turbine etc. Overview of Thermal Power Plant is very important for its better functioning and for its maintenance. The satisfactory design consist of selection of sites; estimation of cost; selection of Boiler, Turbine, Electrical Generator, Cooling System. The Transportation of electrical energy is more economical to the transportation of coal. So, we have to put greater efforts on thermal power plant as it is very economical for us.

Keywords: Economiser, Air Preheated, Boiler, Turbine, eff. (efficiency)

INTRODUCTION

A thermal power station is a power plant in which heat energy is converted to electric power. It depends on the Ranking Cycle. Water is heated, steam is produced and it rotate the steam turbine which drive electrical generator.

After it passes through the turbine, the steam is condensed in condenser. And recycled where it was heated.

FUEL USED

Type- stack coal

General Layout & Basic Idea-

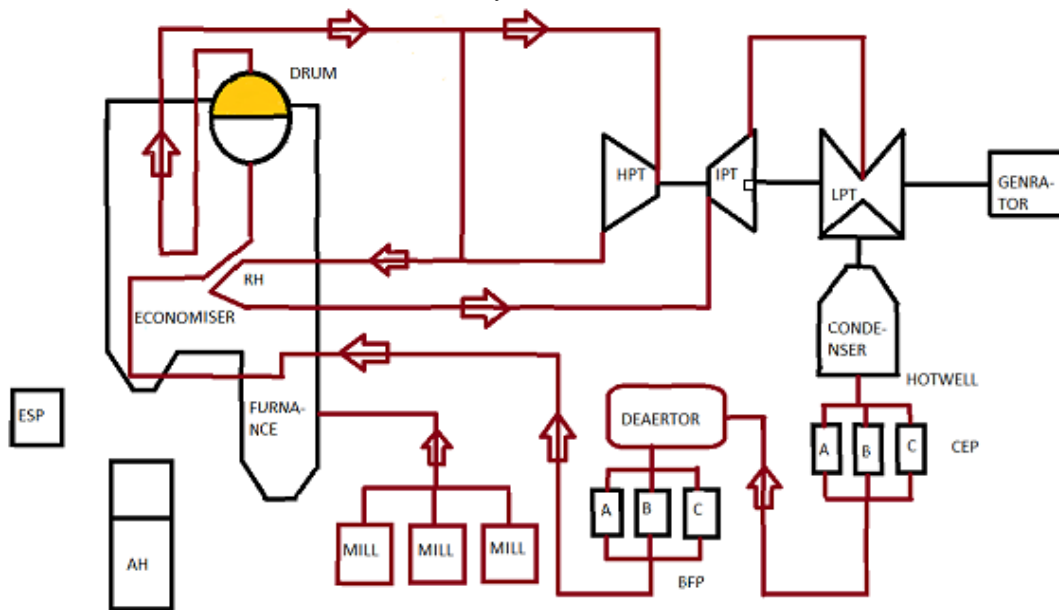

Calorific value -4450-5500 kcal/kg

BOILER- A boiler is a closed vessel in which water, under pressure is converted into steam.

Boiler type-

1. Fire Tube Boiler- In this type the product of combustion pass through the tubes which are surrounded by water.
2. Water Tube Boiler –In this type of boiler water flows inside the tube and hot gases flow outside the tube.

Natural circulation ,tangentially fired, over hanged type. Water tube boiler are used. Oil burner are provided b/w coal burner for initial start up and flame stabilisation. Firstly, light oil (diesel oil) is sprayed for initialisation

than heavy oil(speed diesel oil) is used for stabilization of flame.

Furnace- Furnace is primary part of boiler where the chemical energy available in the fuel is converted into thermal energy by combustion.

Boiler Drum- It is a pressure vessel .Its function is to separate water and steam from the mixture generated in the furnace walls .It provide water storage for preventing the saturation of tubes. Drum is made up of two halves of carbon steel plates having approx. Thickness up to 133-135 m. Boiler drum is located at a height of 53m from ground. Feed Water is supplied to the drum from

economiser through feed nozzles. Water from the drum goes to water walls through down comers.
FANS-

1. DRAUGHT FANS- A fan can be defined as volumetric machine which like pumps moves quantities of air or gas from one place to another. In doing this it overcomes resistance to flow by supplying the fluid with the energy necessary for contained motion.

2. PRIMARY AIR FAN(P.A FAN)-Pulverised coal is directly fed from coal mills to the burner at the four corners of the furnace through coal pipe with the help of heated air coming from P.A FAN. Usually sized for 1500 RPM due to high pressure.

3. FORCED DRAUGHT FAN(F.D FAN)-The combustion process in the furnace can take place only when it receive a steady flow of air. Thus FD FAN takes air from atmosphere at ambient temperature & provide additional draught. Its speed varies from 600-1500RPM.

4. INDUCED DRAFT FAN(I.D FAN)- The flue gases coming out of the boiler are passed to the ESP & then dust free gases are discharged up by the chimney to the atmosphere through the I.D fan.

5. ECONOMISER-The flue gases coming out of the boiler carry a lot of heat. An economiser extract a part of this heat from the flue gases and uses it for heating the feed water before it enters into the steam drum. The use of economiser result in saving fuel consumption and higher boiler efficiency but need extra investment. A large no. of small diameter thin walled tube are placed b/w two header. Feed water enters the tube through the other. The flue gases flow outside the tube.

6. AIR PREHEATERS- Air Preheated are employed to recover the heat from the flue gases leaving the economiser and are used to heat the incoming air for combustion. Cooling of flue gases by 20% raises the plant efficiency by 1%. In some places regenerative type of preheated is used.

They use a cylindrical rotor made of corrugated steel plate. The rotor is placed in a drum which is divided in two compartments, i.e. air compartment(primary air coming from primary air fan and secondary air for air coming from FD fan with +ve pressure) and flue gases (from economiser with -ve pressure) compartments. The rotor is fixed on an electrical shaft rotating at a speed of 2 to 4 rpm.

7. SUPERHEATER- Super heater steam is that steam, which contains more heat than the saturated steam at the same pressure. A Super heater is a device which removes the last trace of moisture from the saturated steam leaving the boiler tubes and also increase its temperature above the saturation temperature.

8. REHEATER- Reheated are provided to raise the temperature of the steam from which part of energy has already been extracted by HP turbine. This is done so that the steam remains dry as far as possible through the last stage of the turbine. A Reheated can also be convections, radiation or combination of both.

TECHNICAL SPECIFICATION OF BOILER(used in KSTPS)

1. TYPE	Direct fired, natural circulation balanced draft water tube boiler
2. No. of units	Two
3. Make	BHEL
4. Capacity	375 tonnes per hour
5. Steam Pressure	139Kg/Cm ²
6. Efficiency	86.6%
7. no. of fans in service	
a) ID Fans	2 Nos.
b) FD Fans	2 Nos.
c) PA Fans	2 Nos.
8. Steam temperature	540 degree Celsius
9. No. of coal mills	3(AB;CD;EF)
10. No. of soot blowers	70 Nos.

STEAM TURBINE- Turbine is a machine a shaft is rotated steadily by impact or reaction of current or stream of working substance(steam, air , water, gases etc.) upon blades of a wheel. It converts the potential or kinetic energy of the working substance into mechanical power by virtue of dynamics action of working substance.

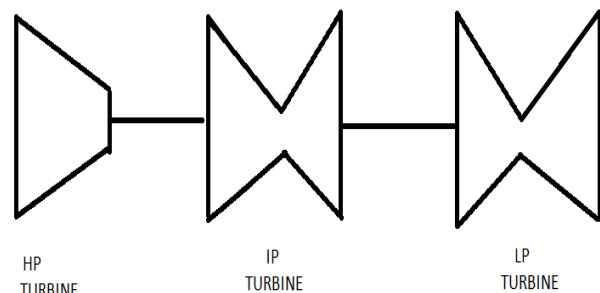

Description of Steam Turbines-

1. High Pressure Turbine(H.P Turbine) –The H.P casing is a barrel type casing without axial joint. Because of its rotation symmetry the barrel type casing remain constant in shape and leak proof during quick change in temperature. The HP turbine consist of 25 reaction stages.

2. Intermediate Pressure Turbine(I.P Turbine) –The IP part of turbine is of double flow construction. The casing of IP turbine is split horizontally and is of double shell construction. The double flow inner casing is supported kinematic ally in the outer casing. The IP Turbine consists of 20 reaction stages per flow.
3. Low Pressure Turbine- The casing of double flow type LP Turbine is of three shell design. The shell are axially split and have rigidly welded construction. The outer casing consist of the front and rear walls, the lateral longitudinal support bearing and upper part. Steam admitted to LP Turbine from IP Turbine flows into the inner casing from both sides through steam inlet nozzles.

TURBINE AUXILIARIES

1. **BEARING GEAR/TURNING GEAR**-It helps to rotate at 3-4rpm speed. It ensure uniform heating &cooling at time of starting & shutdown.
2. **JACK OIL PUMPS**- It reduces frictional and bearing wear.
3. **GLAND SEALING**- It uses to reduce the leakage of steam and air.
4. **GENERATOR**- Thermal power station burns the fuel and use the resultant heat to raise the steam which drives the turbo generator. The fuel may be fossil(coal; oil; natural gas) whichever fuel is used the object is same to convert the heat into mechanical energy by rotating a magnet inside the set of windings.
5. **TURBO GENERATOR** incorporated with most modern design concepts and constructional features, which ensure reliability, with constructional & operational economy. The generator is driven by directly coupled steam turbine at a speed of 3000rpm, the generator is designed for continuous operation at rated output. The source of excitation of rotor windings is thyristor controlled D.C supply.

TECHNICAL DATA

a) GENERATOR(110MW)-

Type	e.g,2,34,602
Continuous apparent power	1,37,500 KVA
Active power	7,10,000 KW
Power factor	0.8(lagging)
Rated Voltage	1000+5% rated
Current	7,220A

Critical speed	3000 rpm
Voltage Regulation	39%
Phase Connection	6
b)HYDROGEN COOLER-	
No. of elements	6
Cooling Medium	Water, Hydrogen
Discharge Losses	1500KW
Quantity of Hydrogen	30 m ³ /sec
Water temperature	34 degree cel.

FSSS (Furnace Safeguard & Supervisory System)-Power System is industrial facility for electric power. The coal fired Power Station is industrial facility for electric power. FSSS is designed to ensure the execution of orderly operating sequence in the start up & shutdown of fuel firing equipment and to prevent error.

COOLING SYSTEM

Hydrogen cooling system is employed for generator cooling. Hydrogen is used for cooling medium primarily because of its superior cooling properties &low density. Thermal Conductivity of hydrogen 7.3 times the air. It also has higher transfer co-efficient. Its ability to transfer heat through forced convection is about 75% better than air.

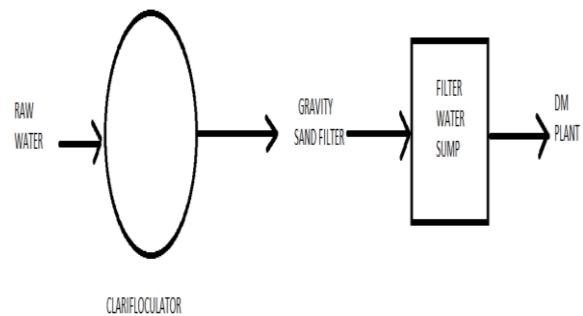

WATER TREATMENT PLANT

The principle problem in high pressure boiler is to control corrosion and steam quality. Internal corrosion costs power station cores of rupees in repair without strict control impurities in steam also form deposits over turbine blades and nozzles.

D.M PLANT (Demineralised Plant) - In this plant process water is fed from all these dissolved salts. Equipment for demineralisation cum softening plant is supplied .This plant consists of two stream with activated carbon filter, weak acid, cat ion exchange and mixed bed exchanger.

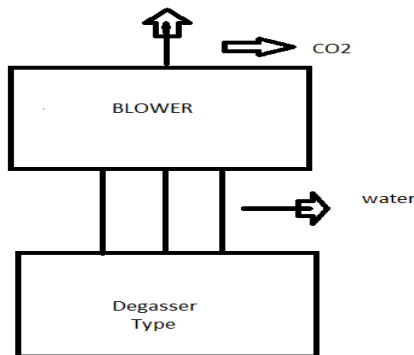

As we know, river is the raw water intake for Thermal Power Plant.

The coagulant used in Thermal Power Plant is

- a) PAC(Poly ammonium chloride)
- b) Chlorine

Strong Acid Cat ion Unit- Cationic resin R-SO₃H (Gel Sulphuric acid)

2.)C.W PLANT- Circulating water pump house has pumps for condensing the steam for condenser.

3.)B.C.W PUMP HOUSE-Filter water after demineralisation is used for bearing cooling from BCW pump house after passing through strainer and heat exchanger at 38 degree Celsius. The raw water used in ash handling plant and remaining quantity is stored in sumps of BCW Pump House.

SWITCHING GEAR-

- 1.) 220 KV System
- 2.) Circuit Breaker
- 3.) Isolators
- 4.) Current Transformer
- 5.) Potential Transformer
- 6.) Lightening Arrestor

Main Control Room-

In control room various control are provided simultaneously various measurement are made various relay are provided here. It has

- a) Fan Control Desk
- b) Fuel Control Desk
- c) Steam & Water Desk
- d) Turbine Desk
- e) Generator Control Panel

EFFICIENCY

Potential energy or chemical energy of the fuel is converted into heat by the process of combustion. Plant efficiency consist of following parts-

- a) Cycle efficiency
- b) Turbo-generator efficiency
- c) Boiler efficiency
- d) Auxiliary Power efficiency

Overall efficiency=Boiler eff.*Turbine eff. *Cycle eff.*Generator eff.

Cycle Efficiency-Energy available for conversion in work/energy given in boiler as heat.

Generator Efficiency-The alternator is very efficient m/c at about 98% efficiency. The losses can be categorised as –

- a) Copper and iron losses
- b) Wind age losses

Boiler Efficiency-It depends upon=

- 1) Dry Flue gas loss
- 2) Wet flue gas loss
- 3) Moisture in combustion loss
- 4) Radiator & Unaccounted loss

It means the efficiency of the steam turbine in converting the heat energy made available in the cycle into actual mechanical work.

REFERENCES

- 1. Faculty and technicians of Training cell of Kota Super Thermal Power Plant guided in summer training.
- 2. B.R. Gupta “GENERATION OF ELECTRICAL POWER” INDIA 2009
- 3. <http://www.rvunl.com/kota thermal power station.php>