



The Effect of Underground Voids on Stability of Foundations: A Review

M.Ramachandran¹, J.Jayamohan², V.I.Beena³

Research Scholar in Civil Engineering, Kannur University, Kannur, India¹

Associate Professor, Civil Engineering, LBS Institute of Technology for Women, Thiruvananthapuram, India²

Professor, Department of Civil Engineering, Government College of Engineering, Kannur, India³

Abstract: Voids may be natural or manmade. The calcareous sediment rocks contain voids as they are susceptible to water dissolution. The voids could also be the result of activities like mining, tunnelling etc. These voids either continuous or discrete, impose a hitch in the smooth designing of foundations. The problem is further aggravated as the foundation is to be designed to withstand seismic forces. The systematic scientific study of the effect of underground voids on the stability of foundation began by mid eighties of the last Century as some laboratory level investigations were initiated in conjunction with numerical studies using Finite Element Method. A series of investigations led to the conclusion that the depth and eccentricity of voids play a vital role in the analysis of stability of foundation. There exists a critical depth and a critical eccentricity beyond which the effect of a void becomes insignificant. Efforts were on to reduce the magnitude of the critical depth and eccentricity. A certain depth of top weak soil can be replaced by a layer of granular fill and the footing made to rest on this prepared layer. The performance can be further improved by reinforcing the granular fill with geo-synthetics. The geo-synthetic reinforcement possess the inherent drawback of excessive settlement during the initial stages of loading which adversely affects the performance of footing over voids. Recent developments in laboratory investigations reveal that this issue can be overcome by using pre-stressed reinforced granular beds, which reduces the initial settlement considerably. The challenge in the present scenario is the economical application of laboratory findings in in-situ activities giving due share to the durability aspects of the Pre-stressed Reinforced Granular Bed.

Keywords: Underground Void, Critical depth, Critical Eccentricity, Multiple Voids, Granular Bed, Prestressed Reinforced Granular Bed.

I. INTRODUCTION

The presence of underground voids can cause serious engineering problems leading to instability of foundations incurring structural damages. The severity of damage depends on the degree of vertical as well as lateral proximity of the voids. The alternatives available to a geotechnical engineer are (a) filling up the void with a suitable bearing material (b) using piles and caissons to penetrate to a depth beyond the void and to bear on soil or rock (c) excavating and placing the footing below the void and (d) shifting the foundation away from the void. These alternatives may be either impracticable or expensive or infeasible. It is desirable to have a systematic analytical approach to design a stable foundation above a void. In the study of bearing capacity behaviour of a strip footing located above a continuous void in silty clay soils [3] observed that there exists a critical depth below which the presence of void has negligible influence on footing performance. A study on the effect of underground void on shallow foundation supported by a compacted clay was conducted by [4] and reached a conclusion that the critical depth is not a constant but varies with the shape of footing and void, void orientation, void size and soil type. An effort was made by [5] to formulate equations for collapse footing pressure of strip footing centred above continuous circular voids. Equations, tables and charts were introduced by [7] to design soil layer geo synthetic systems to span voids such as tension cracks, sink holes, dissolution cavities and depressions in foundation soils due to differential settlement or localized subsidence. The results of analysis using FEM done by [6] indicated that the performance of strip footing is influenced by many factors such as the depth to bed rock for a homogeneous soil deposit, the thickness of bearing stratum and the relative strength between the bearing and underlain strata for a two-layer soil deposit and void conditions including void size and location. The effect of multiple voids on the yielding pressure of strip footing was numerally investigated by [8] using FEM and a practical calculation formula was developed for estimating the yielding pressure. The potential benefits of providing geocell reinforced sand mattress over clay subgrade with void have been investigated through a series of laboratory scale model tests by [9]. The laboratory tests conducted by [10] on footing constructed on unreinforced and geogrid reinforced sand with a circular void subjected to a combination of static and repeated loads revealed that the footing performance due to cyclic loading is better for thicker geogrid reinforced sand with voids than for unreinforced sand with no void.



II. FOOTING ABOVE CIRCULAR VOID

To identify the various factors that critically influence the footing stability [5] used the Finite Element Method along with model footing tests. They studied the use of upper bound theorem of limit analysis to develop equations for strip footing centred above a continuous void. In the analysis the footing was assumed to be a rigid body and the bearing soil was considered as a rigid plastic material. They adopted three failure mechanisms. For each failure mechanism, the rate of energy dissipation along the slip lines, the rate of work done by the soil weight and pressure inside the void were obtained. Then the rate of work done and the rate of energy dissipated were equated and there by the equation for footing pressure required to cause a collapse of the foundation system was developed.

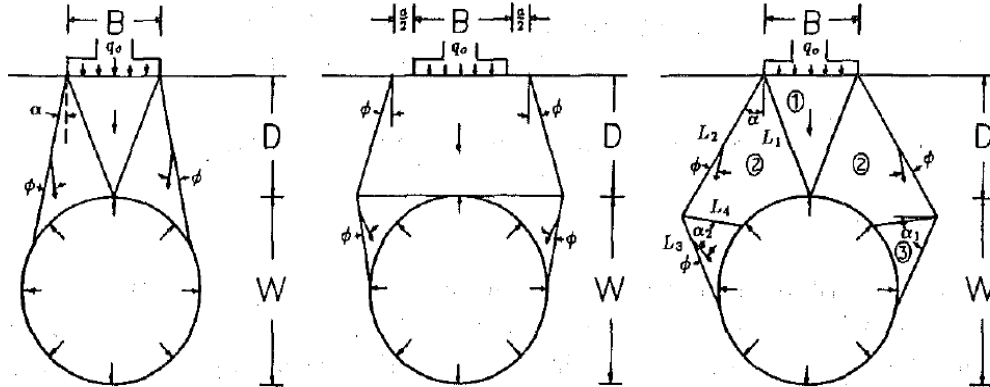

Fig. 1: Failure Mechanisms for Footing Collapse [5]

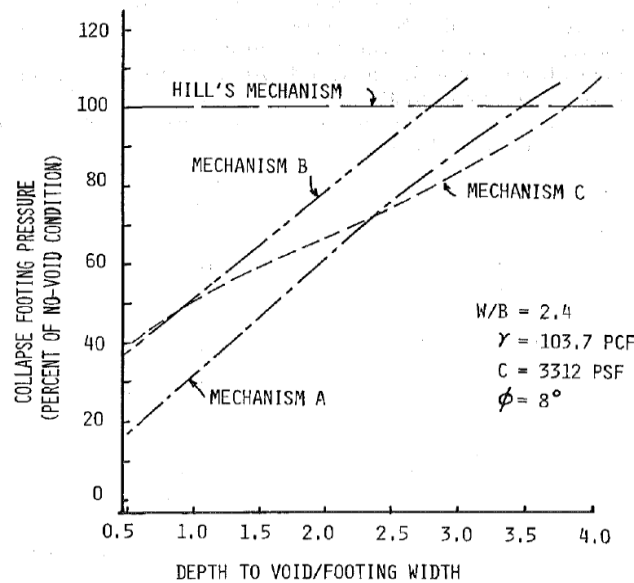

Fig. 2: Variation of Collapse Footing Pressure with Ratio of Void depth to Footing width[5]

Fig. 1 shows the failure mechanisms and Fig. 2 indicates the variation of collapse footing pressure expressed as percentage of non void condition vs the depth of void expressed as a multiple of footing width. Fig 2 also demonstrated that mechanism A dominated when the void was near the footing. As the void goes deeper, mechanism C comes in to action. Mechanism B was not critical .When the depth of void was four times the width of footing, practically the presence of void won't impose any effect on the stability of footing .This depth was designated as critical depth.

III. FOOTING ON SOFT SOIL WITH MULTIPLE VOIDS

The effect of multiple voids on the yielding pressure of strip footing was numerically investigated by [8] using a two-dimensional plane strain Finite Element Method of analysis. Calcareous sediments which are widely available in tropical and subtropical regions were used for the investigations .By nature this kind of soils are crushable and as a result, underground voids are an usual phenomena in these regions .They used the properties of this kind of soil for their investigations and defined a term, Reduction Factor R as,

$$R = q_y/q_{y'} \text{ -----} 1 .$$



Where q_y and q_v = yielding pressure of strip footing on the ground with a void and without void ,respectively. From equation 1 it is understood that a void will not have any influence on the yielding pressure when R equals unity. Fig 3 shows a schematic view of footing and single void system . B and W represent the width of footing and width of void respectively . X represents the eccentricity of the centre of the footing with respect to the centre line of the footing and Y represents the depth of void centre from the ground surface .Fig. 4a shows the pressure below the ground surface normalized by B, based on uniform surface pressure exerted on the strip footing([1]) .The Contour line indicates the ratio of vertical stress to (σ_y) to the loading pressure q .The failure mechanism of strip footing based on plastic theory for the case where the footing is perfectly rough ([2]) is shown in Fig 4b. Fig. 5 shows the behaviour of failure zones as X/B changes for a constant value of Y/B=1.5.In the study of multiple voids [8] defined a Global Reduction Factor

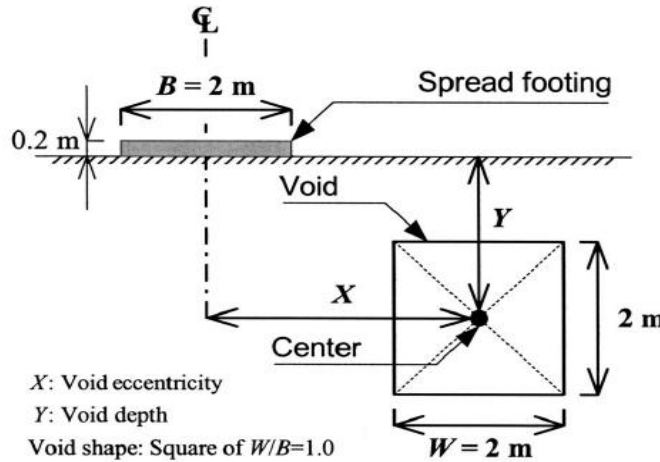

Fig 3: Schematic View of Footing and Single Square Void System[8]

GR for multiple voids as the product of Reduction Factors of individual void.

$$GR = R_A \times R_B \times \dots \times R_N \quad \text{-----2}$$

where R_A, R_B, \dots, R_N are the Reduction Factors for single void A, B,N. The degree of accuracy of Eq.2 may be judged by the index β which is defined as

$$\beta = GR_{FEM} / GR \quad \text{-----3}$$

where GR_{FEM} denotes the GR obtained from FEM . Equation 2 is able to use in practical situations if β is close to unity . Fig 6 depicts configuration of 2 square voids A and B : symmetrical ,parallel ,serial and offset. They plotted the relationship between the values of β and GR for 25mm settlement and yielding pressure (Fig.7) . From Fig. 7a it was observed that for 25 mm settlement, the value of β varied from 1.03 to 0.97. In the case of yield pressure, for symmetric configuration, the value of β varied from 1.43 at GR=0.2 to 1.0 at GR=0.95. But for other 3 configurations value of β was in the narrow range of 1.15 - 1.05 and GR values equal to 0.3 to 0.35. Hence it was concluded that equation 2 is practically valid even though the value of β was slightly on unsafe side for a settlement of 25 mm. Figures 5, 8 and 9 show the failure zones at yielding pressure for various configurations of a single void ,double voids and triple voids respectively .From the results obtained they reached a conclusion that the critical failure mode is always formed through weakest zone with the same value of GR_{FEM} ,regardless of the number of voids and the configuration of voids. The extent of failure was similar to the case of single void and the failure zone was developed towards the nearest void.

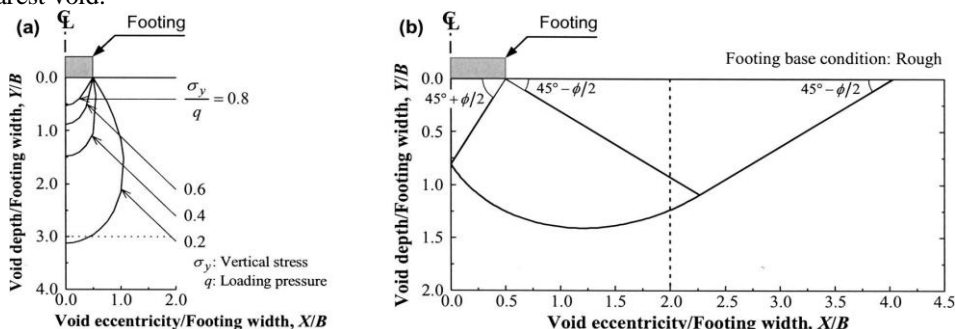

Fig. 4: Point at which Influence of Single Void Disappears :(a)Pressure Bulb resulting from Uniformly Distributed Surface Pressure on Strip Footing (b) Failure Mechanism of Strip Footing based on Plastic Theory [8]

□ Compressive failure

R: Reduction factor

Void shape: Square of $W/B=1.0$

● Tensile failure

W: Void width (2 m) B: Footing width (2 m)

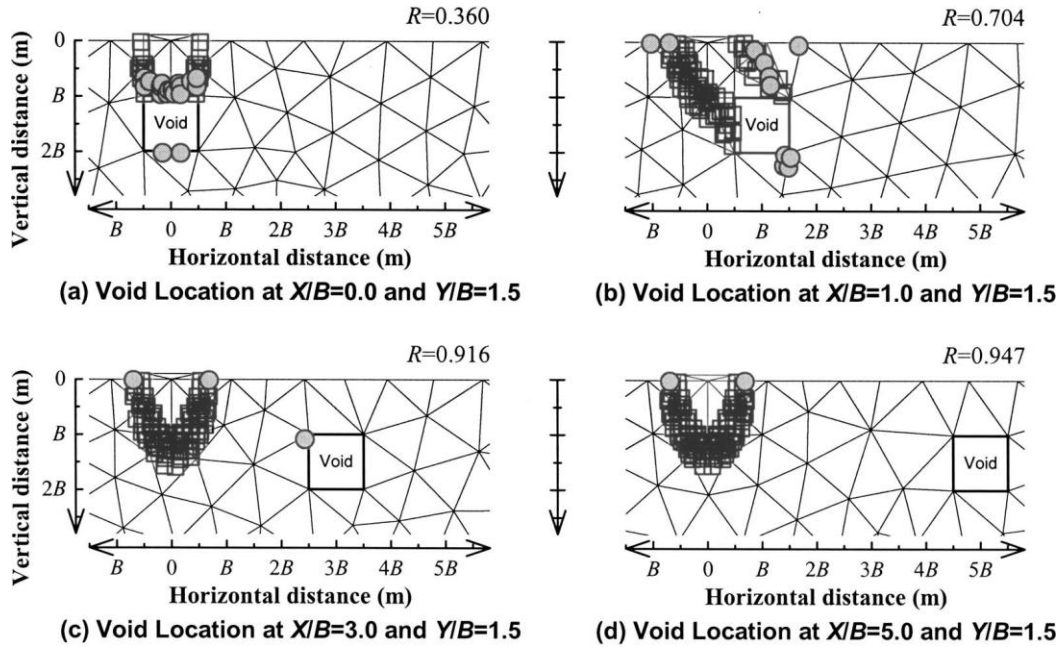

Fig. 5: Failure Condition at Yielding Pressure (q_y) changes with X for $Y/B=1.5$

(a) No-Void Eccentricity (b) $X/B = 1.0$ (c) $X/B = 3.0$ and (d) $X/B = 5.0$ [8]

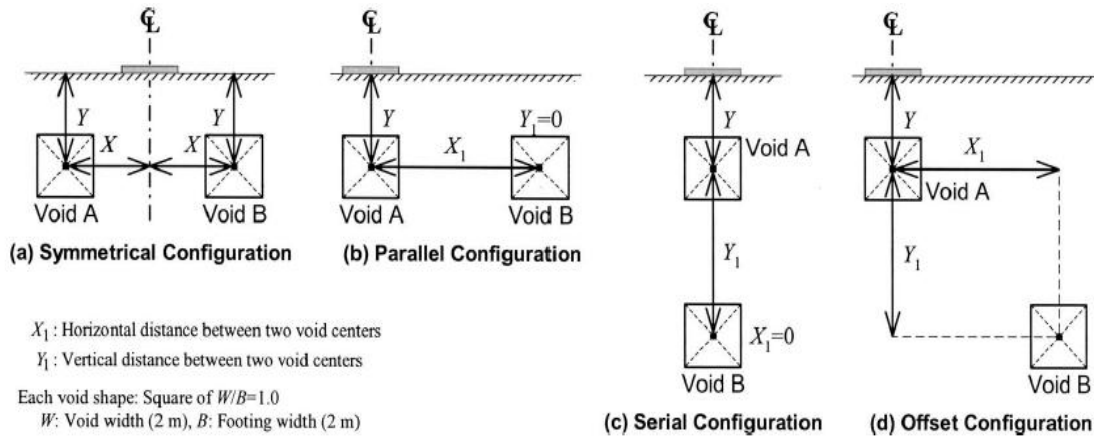

Fig.6: Four Two-Void Configurations: (a) Symmetrical. (b) Parallel (c) Serial (d) Offset [8]

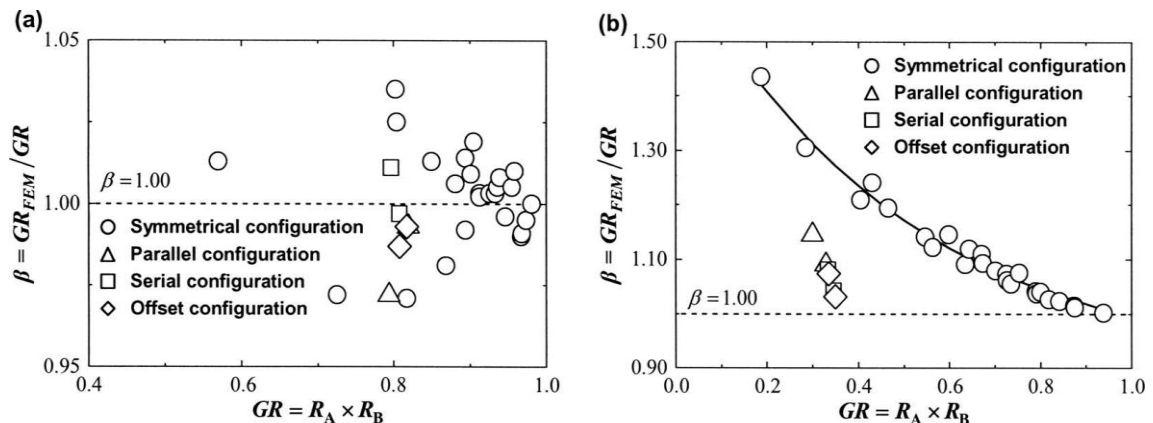

Fig.7: Relationship between β and GR for (a) 25 mm Settlement (b) Yielding Pressure q_y [8]

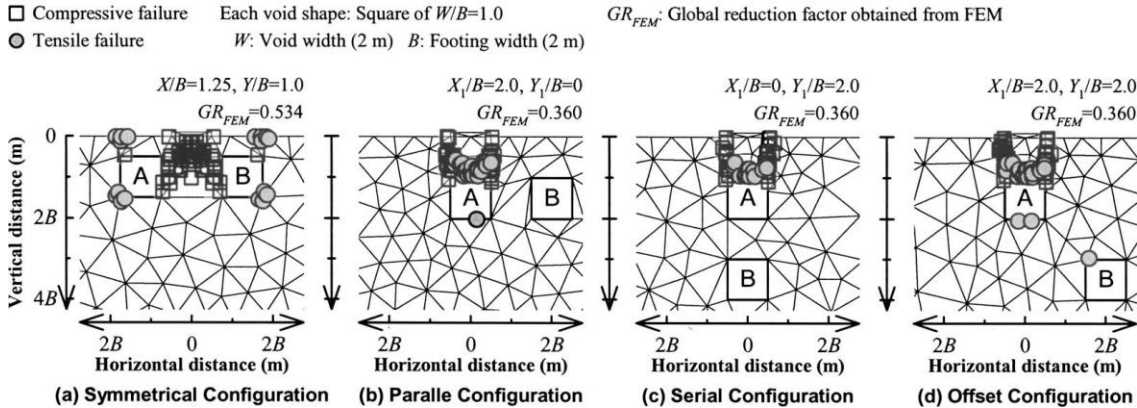

Fig. 8: Failure zones at yielding pressure (q_y) for various configurations [8]

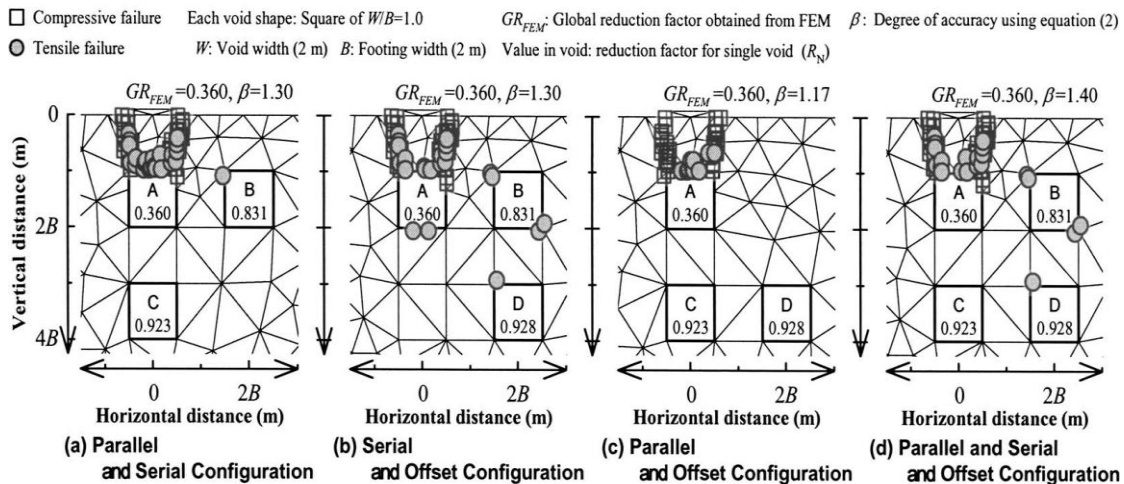

Fig.9: Failure Mode at Yielding Pressure (q_y) for 3 Configurations of Three-Voids and 1 Configuration of Four-Voids [8]

IV. REINFORCED GRANULAR BED

If the thickness of the soft soil above the void is less than the critical depth it is preferable to use an additional layer of granular bearing stratum reinforced with geosynthetic materials and the footing is placed over it. A series of laboratory scale load tests were conducted by [11] to study the behaviour of a strip footing resting on reinforced sand bed overlying weak clayey soil with voids. Biaxial geogrids were used as reinforcement. The results of the experiments were validated by using the Software PLAXIS 2D.

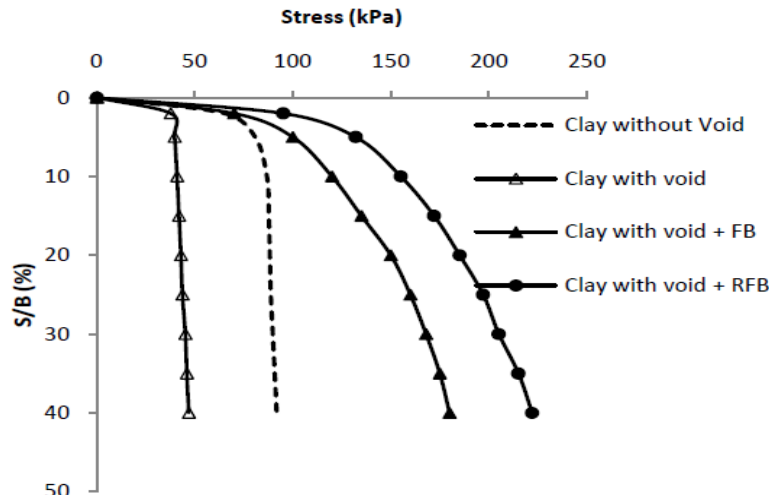

Fig. 10: Vertical Stress vs Normalized Settlement for $Y/B=1$ [11]



Fig. 10 shows the effect of addition of unreinforced and reinforced sand beds over clay with void, above which the footing was laid. The bearing power is improved by the incorporation of sand bed and is further enhanced by providing reinforced sand bed.

V. PRESTRESSED REINFORCED GRANULAR BED

Studies have shown that geo synthetics demonstrate their beneficial effects only after considerable settlements as the strains occurring during initial settlements are insufficient to mobilize significant tensile load in them. This is not a desirable feature for foundations of structures having low permissible settlements. Thus there is a need for a technique which will allow the geo synthetic materials to increase the load bearing capacity without the occurrence of large initial settlements. Prestressing the geo synthetic material may be an answer to this puzzle. The effect of formation of underground voids on the behaviour of a square footing resting on Prestressed Reinforced Granular Bed overlying weak soil was investigated by [12] using the software PLAXIS.

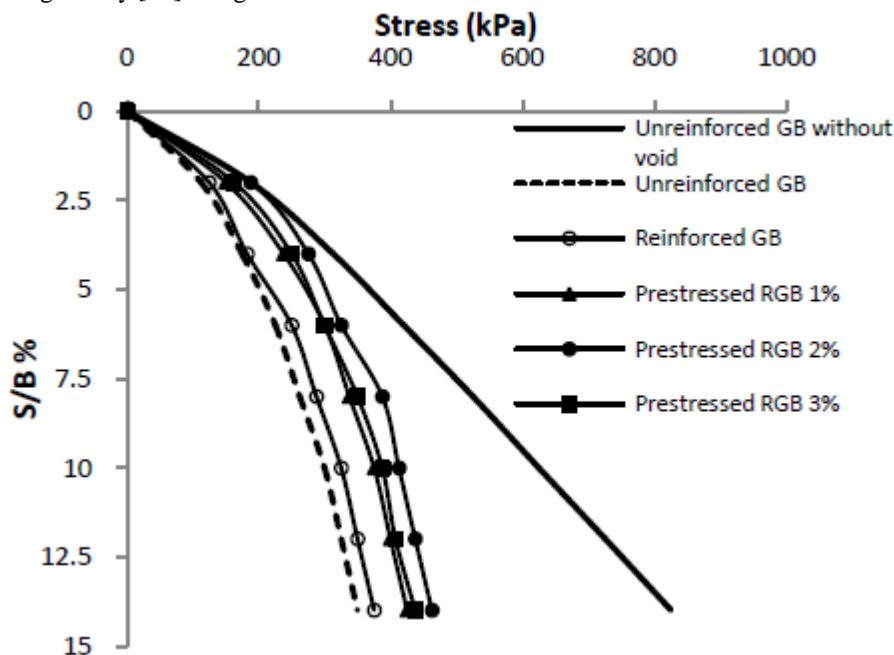

Fig.11: Stress vs Settlement for PRGB with GB Thickness=B, X/B=0 and Y/B=1.0[12]

The graph of Stress vs Normalized settlement curves for values of $Y/B=0.7, 1.0, 1.3$ and 1.75 was plotted keeping the values of $X/B=0$ and Granular Bed thickness=B. They have considered Unreinforced GB with void, Unreinforced GB, Reinforced GB and Prestressed RGB of 1%, 2% and 3% of the tensile strength of geogrid. Fig 11 shows the curves for $Y/B = 1.0$. They observed that bearing capacity increases with the magnitude of prestress up to a certain percentage of prestress, beyond which the bearing capacity is reduced. This is because beyond a certain limit of applied prestress the transfer of stress between the geogrid and the surrounding soil particles shows a downward trend which ends up in a reduction in bearing capacity.

VI. CONCLUSION

The studies and investigations discussed above may be summarised as follows.

1. The underground voids present in soils cause a considerable reduction in Bearing Capacity. There exists a depth and an eccentricity beyond which the effect of voids will be insignificant.
2. Numerical methods may be used to develop failure mechanisms in combination with laboratory model tests.
3. If a single void exists in the ground, the yielding pressure of a footing on the surface is affected by the ratios of void depth and eccentricity to footing width. The failure zone extends from the edge of the footing toward the nearest corner of the void, without forming an active wedge beneath the footing.
4. If there are two voids of same size in the ground, there exists a strong tendency for failure zone to develop near the nearest void. Then the Global reduction factor can be evaluated with reasonable accuracy by multiplying the individual Reduction Factors.
5. If there exists more than two voids of the same size, practically the reduction factor is determined by multiplying the Reduction Factors for the two voids nearest to the footing having a Reduction Factor smaller than 0.9
6. Granular materials like sand above the weak soil with void will improve the bearing power considerably



7. A layer of RGB above the soil can be advantageously used to reduce the critical depth and eccentricity.
8. Prestressed Reinforced Granular Bed can be used to improve the bearing capacity of the soil .Here the problem of large initial settlement is reduced.

VII. SCOPE FOR FURTHER STUDIES

At present the process of prestressing the geosynthetics below footing is in the laboratory testing stage. Moreover, as a footing is meant to transfer the designated load during the entire life of the structure, durability of the Prestressed Reinforced Granular Bed is of utmost concern. The question of developing suitable practical methods of prestressing the geosynthetics at site giving due importance to the durability aspect is still remaining as a challenge.

REFERENCES

- [1]. W.D.Taylor ,Fundamentals of Soil Mechanics , 6th Ed.,Chap. 19,Wiley ,New York,1963 ,p. 566-569
- [2]. K.Terzaghi and B.R.Peck ,Soil Mechanics in Engineering Practice, Chap. IV ,Wiley ,New York, 1967 ,p.217-225
- [3]. R.L.Baus and M.C.Wang ,”Bearing Capacity of Strip Footing above Void” , Journal of Geotechnical Engineering. ASCE,vol.109,No.1,Jan. 1983,p.1-14.
- [4]. M.C.Wang and A.Badie ,”Effect of Underground void on foundation stability” , Journal of Geotechnical and Geoenvironmental Engineering ,ASCE ,vol.111,No.8,Aug. 1985 ,p.1008-1019.
- [5]. M.C.Wang and A.Hsieh ”Collapse Load of Strip Footing above Circular Void” ,Journal of Geotechnical Engineering. ASCE,vol.109,No.1,Jan. 1987,p.511-515.
- [6]. G.Azam ,C.W.Hsieh and M.C.Wang ,”Performance of Strip Footing on Stratified Soil Deposit withVoid” ,Journal of Geotechnical Engineering. ASCE, vol.109,No.1,Jan. 1987,p.753-772.
- [7]. J.P.Giroud, R.Bonaparte, J.F.Beech and B.A.Gross,” Design of Soil Layer-Geosynthetic Systems Overlying Voids”, Geotextiles and Geomembranes,vol.9,1990,p.11-150
- [8]. Makoto Kiyosumi, Osamu Kusakabe, Masotashi Ohuchi and Fang Le Peng ,”Yielding Pressure of Spread Footing above Multiple Voids” , Journal of Geotechnical and Geoenvironmental Engineering. ASCE,vol.133,Dec. 2007,p.1522-1531.
- [9]. S.Sireesh, T.G.Sitharam and Sujit Kumar Dash ,”Bearing Capacity of Circular Footing on Geocell-Sand Mattress Overlying Clay Bed with Void” Geotextiles and Geomembranes, Science Direct,vol.27,2007,p.89-98
- [10]. A.Asakereh,M.Ghazavi and S.N.Moghaddas Tafreshi ,”Cyclic response of footing on geogrid-reinforced sand with void”,Soils and Foundations, The Japanese Geotechnical Society ,vol.53(3),2013,p.363-374
- [11]. J.Jayamohan, P.Rajeev Kumar and Aarya Vimal ,”Effect of Underground Void on the Behaviour of Strip Footing Resting on Reinforced Foundation Bed”, in Proc.50th Indian Geotechnical Conference ,2015,Pune,India.
- [12]. R.Shivshankar and J.Jayamohan ,”Effect of Formation of Voids on the Behaviour of Pre stressed Reinforced Granular beds Overlying Weak Soil”, in Proc.Geosynthetics 2015,Feb. 2015,Portland,Oregon