

# Laser Light Based Voice and Data Transmission and Electric Appliance Automation

Pulkit Swami<sup>1</sup>, Pradeep Singh<sup>2</sup>, Rahul kumar rana<sup>3</sup>, Prashant<sup>4</sup>, Prashant Sharma<sup>5</sup>, Annu Govind<sup>6</sup>

EEE Department, IMS engineering college, Ghaziabad, India<sup>1,2,3,4,5</sup>

Associate professor, Department of Electrical and Electronics Engineering, IMSEC, Ghaziabad, India<sup>6</sup>

**Abstract:** As living in the society, communication is the most important activity of human being. All most for every purpose we are communicating with each other. Different modes of communication are used and voice communication is one of those categories. From the beginning of technological advancement, many processes have been used for the voice communication purpose and among those, Laser Voice Transmission Process is much more useful because of wireless connectivity and free from disadvantage of radio frequency transmission. This paper deals with the designing of a voice and data transmission system which is perfect for information transmission, using an LDR and Laser light. This is easily available in our country. In this analysis we found that the data transmission using laser light is superior in many respects to the conventional communication system. Laser light has higher intensity, efficiency, as well as better visibility and performance quality. It provides a much simpler communication system and reducing the complex wiring.

**Keywords:** LDR, Laser light, Laser Voice Transmission Process.

## I. INTRODUCTION

From the beginning of human living, before the invention of language, communication was the biggest challenge. Human being had always the necessity for communication throughout the history. Initially, communication was done through signals, voice or primitive forms of writing. As time has changed, the necessity of communication through distances was grown to pass information from one place to another. Different ways to exchange information over long distances like pigeons and smoke signals have been adopted in every stages of civilization advancement, some of them have sustained and some has vanished. All these methods were the pioneer of today's modern technological long-distance communication system. This system involves transmission and reception of a large amount of information in a short period of time. Gradually through the technological development, man has invented different procedure of communication with each other.

Now communication has entered in our daily life in many ways like telephone, radio, televisions, cell phone, computer and Internet, in our office and home. Different modes of communication can provide rapid connection from every corner of the globe and even out of the globe (aircrafts, rockets and satellites in space). Along with the wire communication system like telephone, two ways wireless communication system like mobile, internet have become popular now a day. As Laser is stimulated radiation, problem of interference occurs in electromagnetic wave is eliminated, it can be a good substitution of present day communication systems. The laser based voice communication system currently available in market is expensive, in respect to our country's general people income. The people of our country generally use cell phone now days to communicate with each other for general purpose and

sometimes spent hours and money (as call tariff) to talk with next door neighbour, specially young generation. A simple device can be made with minimum cost by cheap electronics parts and Laser torch which is affordable and can be used by general people.

## II. LITERATURE REVIEW

Optical communications has not been started in modern era. The Egyptians invented it before 5000 years by transmitting signal using glass and the Troy fall was transmitted in VI BC by the Greeks through torches. All Modern day optical fiber communication is based on ancient system. The functioning Laser was first operated by Theodore H. Maiman in May 16, 1960 [5] and first visible light laser diode was demonstrated by Nick in almost 1960 [6] and latter it was improved by several scientist of the world including USA at IBM, MIT Lincoln Laboratory, Texas in 1962 [7]. Laser diode is suitable for using in optic communication as it is monochromatic (coherent) light source and easy modulates [8].

Low attenuation optical fiber invented by Kapron in 1970 can be used for communication through Laser in which some amount of power is lost at least [4]. A project has been done to transmit voice data from one station to other for short distance by using different types of high quality and costly lasers such as Gas lasers, Chemical lasers, Excimer lasers, Fiber-hosted lasers, Photonic crystal lasers, Semiconductor lasers, Dye lasers, free electron laser etc where one condenser microphone for capturing sender voice, one transistor BC548 as amplifier, a photo transistor as receiver and a LM386 basic power amplifier IC and 0.5w Speaker was used [9]. In other project, signal was transmitted by using laser torch through laser beam

just like fiber optic communication. In this system, in transmitter a 9v condenser is used for taking the audio signal coupled with laser beam and in receiver an NPN photo transistor, common emitter amplifier and speaker is used [10]. another project of laser torch based voice transmission system was constructed with Laser torch(up to wave length of 920nm), IC 741 as volume controller, BC 548, BD 139 as electrical signal amplifiers, Condenser (electrostatic microphone) in transmitter and IC 741, IC 386, with 2n5777 Photo Transistor and 0.5w/8Ω Speaker in receiver [11]. Robert T. Sparks, Stephen M. Pompea and Constance E. Walker have made one system to transmit music or voice over 350 feet by using laser for class room use in schools. In this project they have used the same receiver which is used in NASA SOFIA Active Astronomy Infrared Kit which consists of radio Shack and small solar cell along with a clip-activated laser pointer and centre tapped audio transformer [3]. Peter Phillips described a low cost laser beam communicator project in 1993 by using visible laser diode (5mW, 650nm) in transmitter [12]. An Idea of wireless voice transmission has been given by Thiyagarajan. K, ECE Department, ASM college of Engineering, Chennai, India, which can be a substitution of optical fiber communication system. In his circuit, he has used resistors of 100R, 1K, 10K, 22K, 100K, 220K, 680K, 1M and 100K Koa trim-pot, Capacitors (10 and 2100 μF electrolytic and 10.1 μF monoblock), microphone, transistors, Laser source and photo transistor as a sensing element [13]. Another circuit of Laser Torch-Based Voice transmission system has been collected from circuit idea by Pradeep. G which contents condenser micro phone, transistor amplifier BC 548, an op-amplifier μA741, 1MΩ variable resistor, Base transistor BD139, a 3V Laser torch, 9V power supply etc in transmitter circuit and an NPN phototransistor as light sensor, two stage amplifier and audio amplifier in receiver circuit [14].

III. PROPOSED MODEL

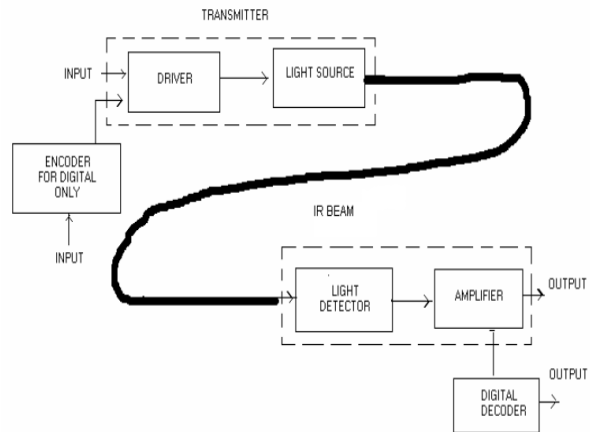

Figure 1: Data Transmission.

IV. USED COMPONENTS

Transmitter: It consists of keypad, microphone, mic, some transistors and an op-amp with attached laser light to transmit the amplified signal. Fig 1.a shows transmitter circuit.

Receiver: It is having microcontroller AT89c52 as the main part and there is a DTMF Decoder to convert light signal into corresponding frequencies. And it is also having LCD and speaker for getting output. Fig 1.b shows receiver circuit

Resistor: Fixed and variable resistor both are used here. Fixed resistors are generally 1k, 10k and 470ohm value and variable resistors are of 1Mohm value.

Photodiode: It is used to receive the laser light signal and also convert the received signal into electrical equivalent.

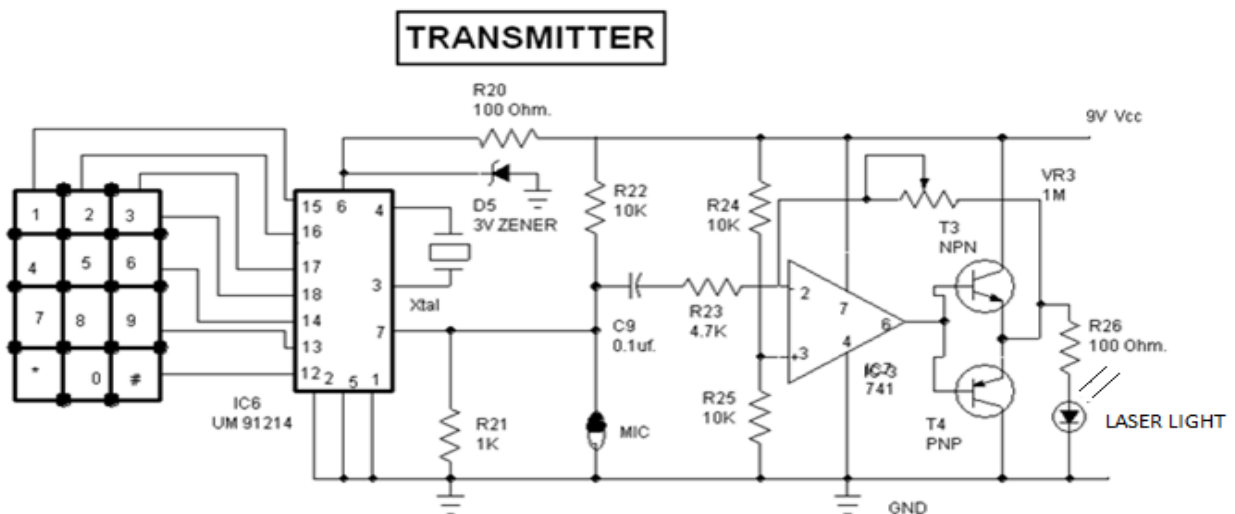

Figure 1.a : Circuit Diagram of Transmitter

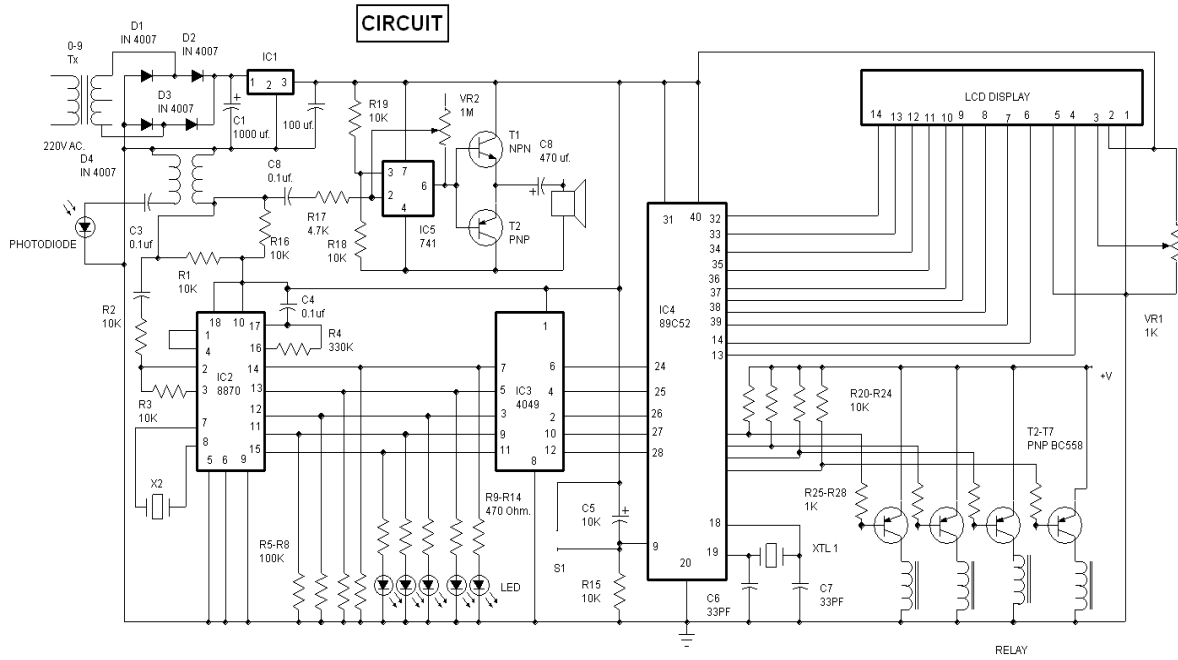

Figure 1.b: Circuit diagram of receiver

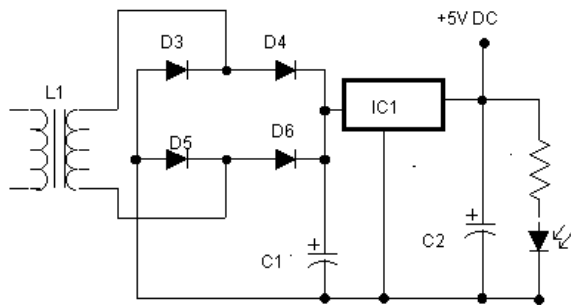

Figure 1.c: Circuit diagram of power supply

collector current [18]. In Fig1. 1a the collector current of the photo transistor, controlled by the incident light on base, flows through the resistor R which determine  $V_o = I_c \times R$ . On the other hand in Fig. 1b the current though LDR, controlled by the resistance of LDR (light intensity) flows through R which determines the output voltage  $V_o = I \times R$ . LDR can be connected in similar way of photo transistor in the receiver circuit as base pin is not connected electrically [18]. However photo transistor has greater sensitivity than LDR and can amplify the current [19]. This problem can be eliminated by using an amplifier at the end of the receiver circuit. Moreover, our designed system cost will be lower than the system we have analysed.

Microcontroller chip: It is thee processing unit of whole prototype.

LCD and Speaker: it is used to get the desired output.

Inverting Buffer: When used in the input section, it acts as a isolator between the controller and the rest of the circuits. When used in the output, it increases the current drive capability.

Power Supply: It favors regulated voltage and 7805 Regulator IC is most suitable here. Fig 1.c shows power supply circuit.

**V. HYPOTHESIS**

The main aim of our project construction was to build a communication system using laser which can be built by the general people quite easily at home with very low cost with the available equipment . The problem faced by photo transistor can be solved by using LDR, a cadmium sulphide cell which has inverse relationship with incident light intensity [16], [17]. Phototransistor is a 2 or 3 pin device and incident light on base determines the amount of

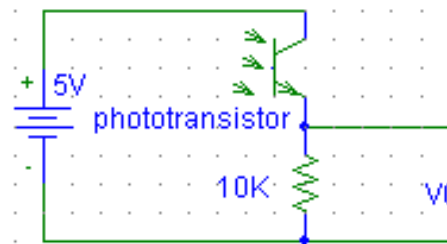

Figure1.1a:Connection of photo transistor in a circuit

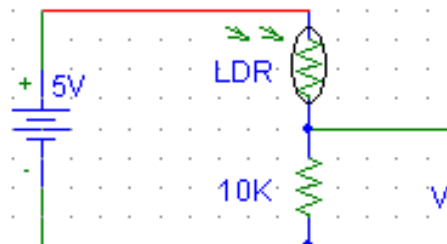

Figure. 1b: Connection of LDR in a circuit

**VI. METHODOLOGY**

To prepare this low cost project, several related circuit diagram has been downloaded from different websites. After verification, a suitable circuit has been chosen for modification according to the equipments available in our country for preparing a low cost design. Flow chart of the total working of the circuit was prepared. The design was modified in such a way so that general people can make it quite easily with affordable equipment. The designed circuit was constructed on a bread board. The transmitter and the receiver circuit were tested differently and every stage output was examined carefully by using 9V eveready battery. Among different stage test, first the transmitter was tested using general laser torch available in anywhere in the market. Electronic equipment have been changed in different stages according to the need and availability in order to get proper output with the possible minimum cost. After getting desired output, the efficiency as well as the range of the system was verified. Comparison of cost of this system and available low cost system has been done. "Fig. 2" shows total working order of the system on the flowchart starting from the transmitter to the receiver output.

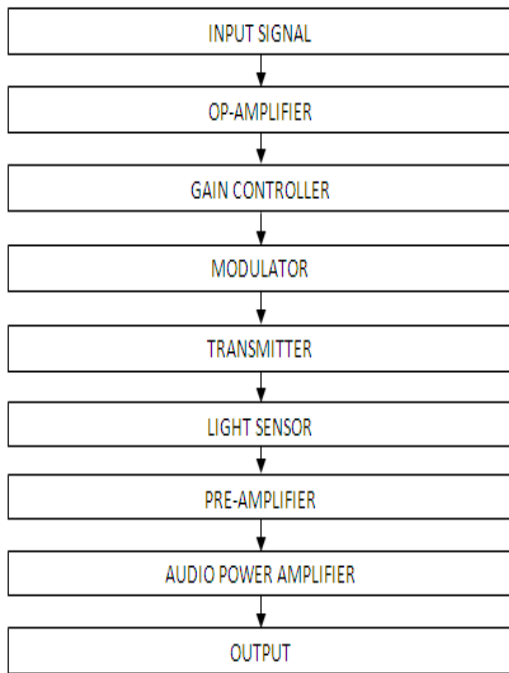

Figure2.Flow chart of total working order of the system

**A. Design and Working of the System**

There were two sections, transmitter and receiver, both powered by a separate 9V fixed voltage power supply. The transmitter board contained a microphone and a laser torch at opposite ends. The electronics equipment controlled the intensity of the laser beam according to the output of the microphone. An LDR was in the receiver as a receiving element and the high gain amplifier with a basic audio output stage powers a small speaker.

Laser torch starts emitting light after its threshold current. The output light is proportional to the current through the

torch. Amplitude modulation can lessen the distortion in laser beam output. A 650nm, 5mW laser torch used in this project can give its maximum output with a threshold current of 30mA. Further increasing the current can damaged the torch.

**B. Transmitter Circuit Operation**

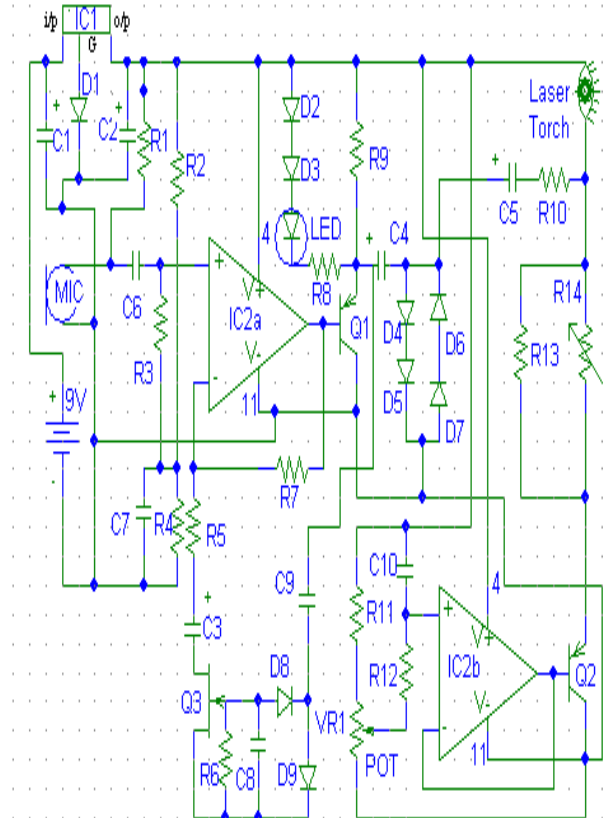

Figure 3. Laser torch based voice transmitter circuit.

In "Fig. 3", an adjustable current source was used through which the laser torch was being supplied. A thermistor (68ohm NTC) was used to minimize the effect of temperature as the threshold current of lased torch is temperature sensitive; heat sink was not used here. Q2 controlled the quiescent current of laser torch which was operated by buffer stag IC2b. The base current of Q2 controlled the collector current of transistor as well as the current through laser torch. The overall system sensitivity and the intensity of the Laser beam depended upon the adjustment of VR1. The audio modulation voltage comes from the emitter of Q1, an emitter follower stage driven by audio amplifier stage IC2a, was faded to the + polarity of the laser torch and the laser current varied by around +/- 3mA beyond its set point. Diodes D4 to D7 was used to limit the modulating voltage at +/-1.4V and capacitors C4 and C5 were used to block the DC voltages at the emitter of Q1 as well as the end of the laser torch. R10 limited the current (audio signal variation) to the laser torch to few mA. LED1 was used to give the indication of modulation signal and Diodes D2, D3 and resistor R8 was for limiting current through LED1 FET Q3 and its associated circuitry eliminated the problem of constant level of output (independent of the audio level at microphone) through



inverting amplifier IC2a, which has a form of compression. C9, D8, D9 and C8 were used as cascaded voltage doublers to rectify the audio signal for feeding to the emitter of Q1 which caused a negative DC voltage at the gate of Q3. When the audio signal was increasing, the negative bias as well as drain-source resistance of Q3 was increasing as R7, R5 and effective resistance of Q3 determined the gain of IC2a. Clamping network (D4-D7) neutralized the effect of sudden voltage rise during the time of compression circuit response. The microphone was powered through R1 which was faded to the non inverting input of IC2a through C6 because fixed DC voltage output was needed to bias Q1. IC1 (5V three terminal regulator) was used to regulate the supply voltage.

### C. Receiver Circuit Operation

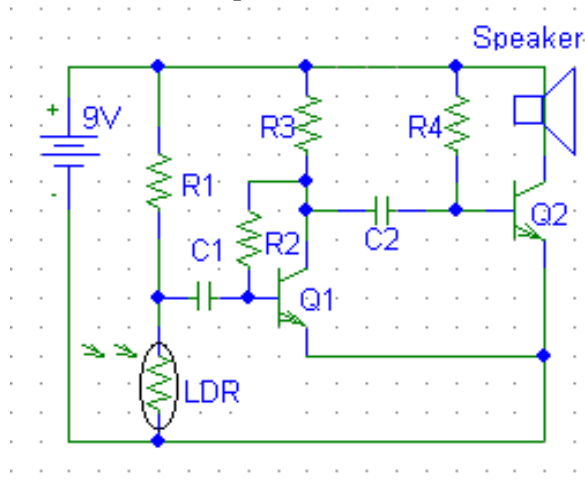

Figure 4. Laser torch based voice receiver circuit.

In “Fig. 4,” the Transmitted Laser beam was detected by LDR whose resistance is inversely proportional to the intensity of receiving light. As LDR is typically used in voltage divider circuit, a resistor R1 was used to drop voltages of supply before connecting to the LDR [16]. A two stage Signal amplifier, Q1 and Q2 in RC coupling with C1 and C2 was used to amplify the receiving audio signal before fading to speaker [20]. Fixed bias and collector to base bias was used for proper operation of the amplifiers using R2, R3, R4 [21]. The value of the resistors was fixed after the physical experiment in trial and error basis.

### VII. RESULT

LDR can work in a similar way of photo transistor, photo diode as well as solar cell in care of receiving photo signal. LDR has other advantage over photo transistor is that, it does not need proper biasing for working and easy to use and get here and there. The laser voice transmission system price available in market is 614 USD and the lowest cost laser transmission system was designed at 60 USD by Robert T. Sparks, Stephen M. Pompea and Constance E. Walker of National Optical Astronomy Observatory, Tucson, Arizona, USA [3]. And the price of used in our project is very less.

### VIII. ADVANTAGES

A remarkable feature of laser is the concentration of its energy to extremely high intensities that’s remaining almost constant over long distances because of low divergence. The main advantage of this system is high reliability as it is impossible to track the data on the way of transmission [12]. That is why this design can be used for transmitting confidential data as well as for general conversation. This design of Laser voice transmission system can be made at home with minimum cost and can be used for frequent conversation between neighbouring house at free of cost instead of using cell phone.

### IX. CONCLUSION

Laser are used today in domestic and international network. These optical system eventually provide the bandwidth that is in such demand. Laser Torch Based Transmission and Reception are cheaper and simpler in construction than RF transmitter and receiver. Infra-Red and Blue-Tooth can also be used for voice transmission and Reception purpose, but their range is small compared with their price. This project can be made and used successfully at conference room, political assembly, and class room and for general conversation between two houses. It is better to use for general conversation with neighbours where confidentiality is a prime issue.

#### A. Limitation

This system cannot be used for communication where there is any obstrucater like hills between two communicated places. But the receiver and the transmitter can be set at the top of the high rise building. But still birds can cause the disturbance in between the receiver and the transmitter.

#### B. Scope for the Future Work

Improved design of this system can be used to transmit confidential voice data from one hill top to other hill top in remote area where cell phone communication is not possible due to the lack of mobile operator’s tower by using extra amplifying circuit at the receiver end for having higher efficiency of the system.

### REFERENCES

- [1] W. Tomasi. *Advanced Electronic Communication System*, 6th ed.. New Jersey, U.S.A, Prentice-Hall, 2004, pp. 3, 41-42.
- [2] S. Kum. (2012). Advantages of laser torch based voice transmitter and receiver. [Online]. Available: <http://sawaal.ibibo.com/electronics-and-gadgets/advantages-laser-torch-based-voice-transmitter-receiver-1952966.html>
- [3] R. T. Sparks, S. M. Pompea, and C. E. Walker. (16 February 2013). *The Development of a Low-Cost Laser Communication, National Optical Astronomy Observatory*, Tucson, Arizona, USA. [Online]. Available: <https://spie.org/etop/2007/etop07k12IX.pdf>
- [4] J. S. Dhindsa, “Performance analysis of various scheduling and routing techniques for optical network,” M.S. thesis of Electronics and Communication Engineering department, Thapar University, India, 2011, ch. 1, pp. 1-10.
- [5] Mr. EHLERS, A resolution submitted to the Committee on Science and Technology in 111th Congress, 2nd Session (recognizing 50th Anniversary of the LASER), Authenticated U.S Government Information, 2010, pp. 2.

- [6] S. C. Singh, H. B. Zeng, C. L. Guo, and W. P. Cai, *Nanomaterials: Processing and Characterization with Lasers*, 1st ed. Wiley-VCH Verlag GmbH & Co. KGaA., 2012, ch. 1, pp. 1.
- [7] I. Melngailis, "Laser development in Lincoln laboratory," *The Lincoln Laboratory Journal*, vol. 3, no. 3, pp. 347, 1990.
- [8] S. Gibilisco, *The Illustrated Dictionary of Electronics*, 8th ed. New York, U.S.A, McGraw-Hill, 2001, pp. 399.
- [9] 1000 Projects. (2012). *Laser Torch Based Voice Transmitter and Receiver Block Diagram*. [Online] Available: <http://1000projects.org/laser-torch-based-voice-transmitter-and-receiver-block-diagram.html>
- [10] 1000 Projects. (2012). *Laser Torch Based Voice Transmitter and Receiver*. [Online]. Available: <http://1000projects.org/laser-torch-based-voice-transmitter-and-receiver.html>
- [11] 1000 Projects. (2012). *ECE Mini Project Report on Laser Torch Based Voice Transmitter and Receiver*. [Online]. Available: <http://1000projects.org/ece-mini-project-report-on-laser-torch-based-voice-transmitter-and-receiver.html>
- [12] Peter Phillips. (1997). *Laser link communicator, electronics Australia*. [Online]. Available: <http://captain.haddock.8m.com/laser/laser1.html>
- [13] K. Thiyagarajan. (2011). *Wireless Voice Communication Using Laser*. [Online]. Available: <http://www.scribd.com/doc/47807263/Wireless-Voice-Communication-Using-Laser>
- [14] G. Pradeep. (2002). *Laser Torch-Based Voice Transmitter and Receiver, Circuit Ideas, Electronics for You*. [Online]. Available: [http://www.proddec.org/circuit/jan02\\_lasertorch.pdf](http://www.proddec.org/circuit/jan02_lasertorch.pdf)
- [15] M. S. Islam and M. A. Rahman, "Design and fabrication of line follower robot," *Asian Journal of Applied Science and Engineering*, vol. 2, no. 2, pp. 27-32, 2013.
- [16] I. R. Sinclair and J. Dunton, *Practical Electronics Handbook*, 6th ed. Oxford, U.K, Newnes, 2007, pp. 252-255.
- [17] O. Bishop, *Electronics Circuits and Systems*, 4th ed. Oxford, U.K, Newnes, 2011, pp. 14.
- [18] T. L. Floyd, *Electronic Devices*, 6th ed. Singapore, Pearson Education, 2002, pp. 559-561.
- [19] C. M. M. Paschoal, D. Do N. Souza, and L. A. P. Santo, "Characterization of three photo detector types for computed tomography dosimetry," *World Academy of Science, Engineering and Technology*, no. 56, pp. 92-95, August 2011
- [20] S. Barua. (2012). *Laser Communication System*. [Online]. Available: <http://circuitdiagrampack.blogspot.com/2012/12/laser-communication-system.html> [Accessed 25 October 2013] .