



STABILITY ENHANCEMENT OF SINGLE MACHINE INFINITE BUS SYSTEM USING SOLAR PV CELL

Gyanesh Singh

Assistant Professor EN deptt. IMS Engg College Ghaziabad.

ABSTRACT: The aim of this work is to study the dynamic performance and stability enhancement of Single Machine Infinite Bus System (SMIB) using solar pv cell. HPFC is an advanced FACTS controller which can be installed in a transmission line between the two electrical areas. The main advantage using HPFC is that it can be used to replace or supplement existing equipments. In the present thesis the Phillips-Heffron Model of SMIB Systems are presented. A proposed model of HPFC is presented and incorporated with SMIB models for analysis of the enhancement of stability. All these models are simulated using MATLAB/SIMULINK. Simulation results show that the designed controller has an excellent capability in damping power system oscillations if HPFC parameters are selected carefully. The results when compared to that of existing FACTS controllers show that HPFC gives better performance. The significance of the results are better stability and constant power supply.

Keywords: Model of SMIB Systems, FACTS controllers, Model of HPFC, MATLAB/SIMULINK. Simulation

POWER SYSTEM STABILITY

1.1 INTRODUCTION

Power system stability has been recognized as an important problem for secure system operation since the 1920s. Many major blackouts are caused by power system instability. As power systems have evolved through continuing growth in interconnections, use of new technologies and controls, and the increased operation in highly stressed conditions, different forms of system instability have emerged. A clear understanding of different types of instability and how they are interrelated is essential for the satisfactory design and operation of power systems.

1.2 DEFINITION OF POWER SYSTEM STABILITY

Power system stability is the ability of an electric power system, for a given initial operating condition, to regain a state of operating equilibrium after being subjected to a physical disturbance as in Fig.1.1 with most system variables bounded so that practically the entire system remains intact.

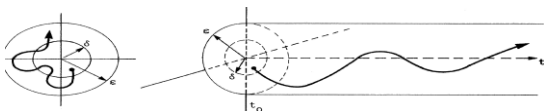
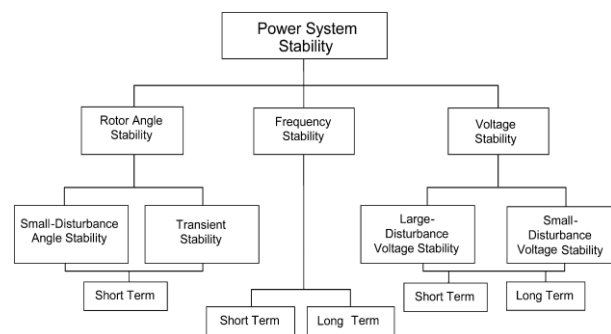
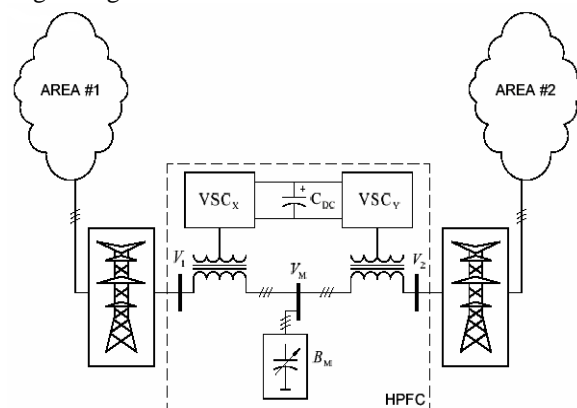

Fig.1.1 Illustration of the Definition of Stability



1.3 HYBRID POWER FLOW CONTROLLER

A block diagrammatic view of the envisioned typical HPFC application is shown in Fig.1.3. The HPFC is installed on a transmission line that connects two electrical areas. In general, its point of installation will be “within” the transmission line, i.e. at some distance from strong voltage busses.





2.3 INFERENCES DRAWN OUT OF LITERATURE REVIEW

i) The investigator found that the power system is a highly non-linear system. Transient stability is affected with small signal and large signal disturbance. Small signal disturbance means change in loads, while large signal due to short circuit and loss of generation.

ii) After searching and reviewing a number of papers, text books and journals the investigator concluded that much work has been done in the field of stability enhancement of Single Machine Infinite Bus (SMIB) System implemented with different FACTS devices.

- Different modeling techniques.
- Heffron-Phillips model.
- Cost effectiveness of different FACTS devices.

iii) In Hybrid Power Flow Controller (HPFC) two topologies have been defined. The first one consists of a shunt connected source of reactive power, and two series connected voltage-sourced converters – one on each side of the shunt device. The second topology is a dual of the first; it is based on two shunt connected current-sourced converters around a series connected reactive element.

iv) A dynamic control scheme of HPFC is presented in which the validity of the mathematical model and feasibility of active and reactive power flow in the controller has been evaluated.

v) Simulation of HPFC has not been done by incorporating in SMIB.

vi) In order to damp Low Frequency Oscillations (LFO), adaptive neuro-fuzzy controller for UPFC is designed and simulated. Simulation is performed for various types of loads and for different disturbances. Simulation results show good performance of neuro-fuzzy controller in damping LFO.

vii) The Adaptive Neuro Fuzzy UPFC controller adjusts control signals by appropriate processing of the input signals, and provides an efficient damping. The results of the simulation show that the UPFC with Adaptive Neuro Fuzzy controller is more effective in damping LFO compared to UPFC with PI controller.

viii) Model Predictive Control based FACTS controller for real time emergency control of WAM based power system has been incorporated.

ix) Detailed investigation have been carried out considering two controllers like Power System Stabilizer (PSS) and Power Oscillation Damping (POD) controller under variation of mechanical disturbances which provides robust performance for SMIB power system.

x) PSASP (Power System Analysis Software Package) is a package of programs widely used in China for power system analysis and simulation. It provides rich functions for user development, including user defined models and user routine interface.

xi) The STATCOM based on voltage source converter (VSC) is used for voltage regulation in transmission and distribution systems.

xii) An investigation on transient stability of power systems equipped with a Static Synchronous Series Compensator (SSSC) as a FACTS device has been carried out

xiii) The use of FACTS devices improves voltage and transient stability and power oscillation damping.

xiv) A modified Heffron-Phillips's (K constant) model has been derived for the design of power system stabilizers. Knowledge of external system parameters, such as equivalent infinite bus voltage and external impedances or their equivalent estimated values is required for designing a conventional power system stabilizer.

xv) The extended Phillips-Heffron model of a single-machine infinite-bus power system installed with a FACTS-based stabilizer, the conventional frequency-domain phase compensation method is applied to design the FACTS-based stabilizer.

2.4 SCOPE OF THE WORK

i) Phillips-Heffron modeling for Single Machine Infinite Bus (SMIB) System can be simulated using MATLAB/SIMULINK.

ii) Simulation of Hybrid Power Flow Controller incorporated in SMIB.

iii) In Hybrid Power Flow Controller (HPFC) two topologies have been defined. The first one consists of a shunt connected source of reactive power, and two series connected voltage-sourced converters – one on each side of the shunt device. The second topology is a dual of the first; it is based on two shunt connected current-sourced converters around a series connected reactive element.

iv) A dynamic control scheme of HPFC is presented in which the validity of the mathematical model and feasibility of active and reactive power flow in the controller has been evaluated.

2.5 PROBLEM FORMULATION

The aim of this work is to study the dynamic performance and stability enhancement of Single Machine Infinite Bus System (SMIB) equipped with Hybrid Power Flow Controller (HPFC).

This has been executed by simulating the following:

- i) Heffron-Phillips model of SMIB.
- ii) Hybrid power flow controller (HPFC).
- iii) Incorporating HPFC into SMIB model.

Linear analysis techniques have been used to study the dynamic behavior of SMIB system with a hybrid power flow controller. MATLAB/SIMULINK has immersed very popular tool and are very widely used for modeling and simulation of systems. This software environment has been used for simulating the present problem.

In this chapter some of the relevant papers regarding facts controllers specially hybrid power controller have been discussed. Inferences drawn out after conducting the literature review has been presented and from which the scope of the work and problem statement has been realized. The software implementation of SMIB



system equipped with HPFC has been discussed and the simulation results have been chalked out in the subsequent chapters.

The transfer function model of any series controller can be depicted as shown in Fig.3.1. The advantage of using transfer function model is that the change in rotor speed can be directly converted into compensation required by the controller.

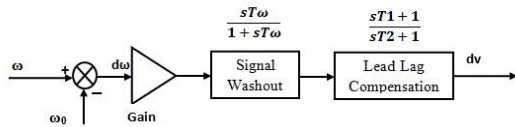

Fig.3.1 Transfer Function Model Series FACTS Controller

The signal washout block serves as a high pass filter with the time constant Tw high enough to allow signals associated with oscillations in speed deviation to pass unchanged. Without it steady changes in speed would modify the terminal voltage. It allows the controller to respond only to changes in speed. The phase compensation block with time constants T1 and T2 provide the appropriate phase lead/lag characteristics to compensate for the phase lag between the input and the output signals. The gain determines the amount of damping introduced by the device.

When a shunt FACTS device is installed the system, the Philips Heffron linear model of a single machine infinite bus (SMIB) power system is modified to include the influence of the FACTS device on the system performance.

By linearizing the equations at an operating condition of the power system, the Philips Heffron model of the power – system with a shunt FACTS controller can be modified as shown in Fig.1.2.

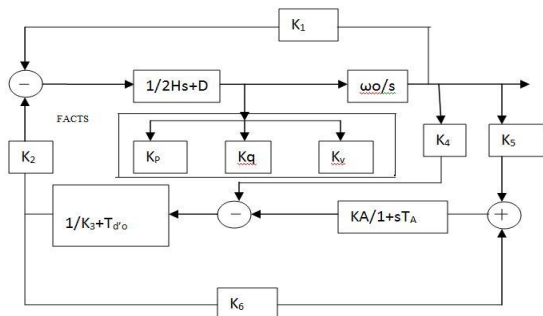

Fig.3.2. The Philips Heffron Model of SMIB with Shunt FACTS controller

The HPFC model is obtained by devising a combination of both the transfer function models of shunt and series controllers. The Philips Heffron model of a SMIB system has been simulated using MATLAB/SIMULINK with and without the proposed HPFC model and stability investigation have been carried out.

3.3 SIMULATION RESULT OF SMIB WITHOUT HPFC

The Philips- Heffron model of an SMIB system without any FACTS controller or HPFC as per FIG.1.11 has been simulated using MATLAB/SIMULINK. The MATLAB/SIMULINK model of SMIB system without HPFC is as shown in Fig.3.3.

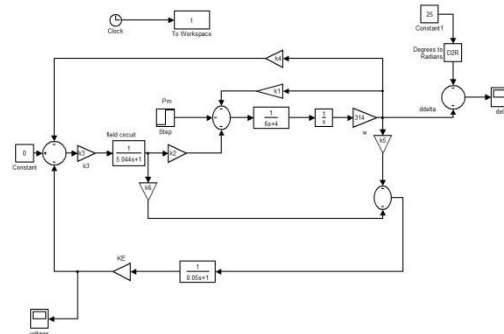

Fig. 3.3 Simulation Model for SMIB without Hybrid Power Flow Controller

The model in Fig.3.3 has been analyzed for stability studies by subjecting to small disturbance by varying the mechanical power ΔPm and exciter gain KE.

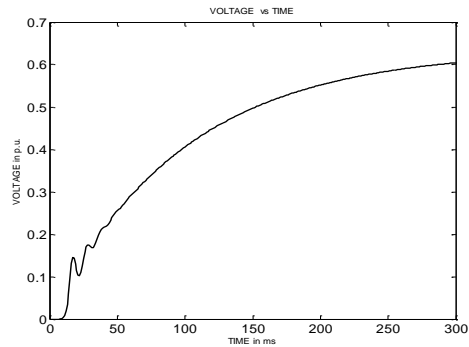

Fig. 3.4 Variation of Terminal Voltage for KE=1 with ΔPm= 0.01 p.u.

Fig.3.4 shows variation of terminal voltage when subjected to small disturbance of mechanical power(ΔPm) = 0.01 p.u. with Exciter gain (KE) =1 and Hybrid Power Flow Controller (HPFC) is not functioning and system become unstable. The system behavior in respect to system voltage is again obtained by increasing the value of ΔPm = 10 and KE = 100 and found to be stable as shown in Fig. 3.5.

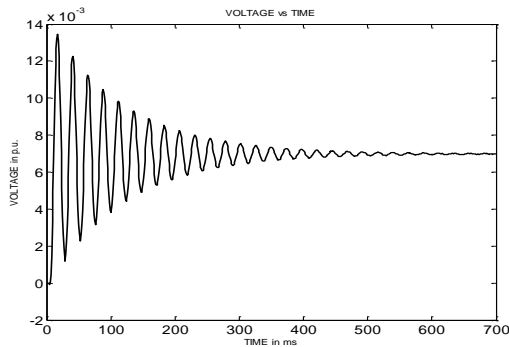

Fig. 3.5 Variation of Terminal Voltage for $K_E=100$ with $\Delta P_m=10$

Similarly the variation of rotor angle with time has been plotted after subjecting the system with similar disturbances. Fig. 3.6 shows the variation rotor angle $K_E = 1$ and $\Delta P_m = 0.01$ p.u. and the figure depicts that the system becomes unstable. Fig. 3.7 shows the variation of rotor angle with $K_E = 100$ and $\Delta P_m = 10$ and the system is stable.

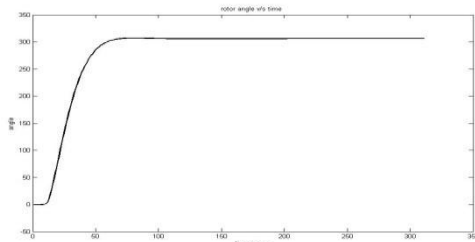

Fig. 3.6 Variation of Rotor Angle for $K_E=1$ and with $\Delta P_m=0.01$ p.u

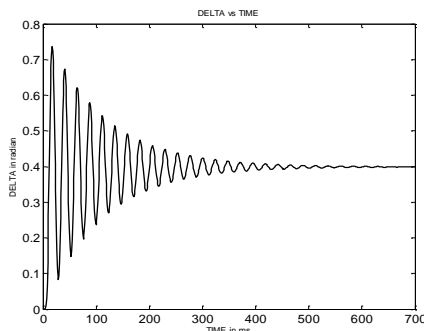

Fig. 3.7 Variation of Rotor Angle for $K_E=100$ with $\Delta P_m=10$

Analysis was done for various values of K_E varying from 0.01 to 100 and ΔP_m varying from 0.01 to 100 and tabulated in Table 3.1. Table 3.1 shows that without HPFC the system goes to instability for all values of ΔP_m . The exciter gain has to be increased to very high value and thus damping has been improved to maintain the system stable.

Table 3.1 Peak overshoot and settling time of system voltage and Rotor angle with variation in mechanical power and Exciter gain without incorporating HPFC

Mechanical Power ΔP_m in p.u.	Exciter Gain K_E	System Voltage		Rotor Angle	
		peak overshoot in p.u.	settling time in ms	peak overshoot in p.u.	settling time in ms
0.01	0.01	unstable	unstable	unstable	unstable
0.1	0.01	unstable	unstable	unstable	unstable
1	0.01	unstable	unstable	unstable	unstable
10	0.01	unstable	unstable	unstable	unstable
100	0.01	unstable	unstable	unstable	unstable
0.01	0.1	unstable	unstable	unstable	unstable
0.1	0.1	unstable	unstable	unstable	unstable
1	0.1	unstable	unstable	unstable	unstable
10	0.1	unstable	unstable	unstable	unstable
100	0.1	unstable	unstable	unstable	unstable
0.01	1	unstable	unstable	unstable	unstable
0.1	1	unstable	unstable	unstable	unstable
1	1	unstable	unstable	unstable	unstable
10	1	unstable	unstable	unstable	unstable
100	1	unstable	unstable	unstable	unstable
0.01	10	unstable	unstable	unstable	unstable
0.1	10	unstable	unstable	unstable	unstable
1	10	unstable	unstable	unstable	unstable
10	10	unstable	unstable	unstable	unstable
100	10	unstable	unstable	unstable	unstable
0.01	100	unstable	unstable	unstable	unstable
0.1	100	unstable	unstable	unstable	unstable
1	100	unstable	unstable	unstable	unstable
10	100	Stable for higher value	Settled fast	Stable for higher value	Settled fast
100	100	Stable for higher value	Settled fast	Stable for higher value	Settled fast

3.4 SIMULATION RESULT OF SMIB WITH HPFC

The Philips- Heffron model of an SMIB system with FACTS controller or HPFC as per FIG.1.11 has been simulated using MATLAB/SIMULINK. The MATLAB/SIMULINK model of SMIB system with HPFC is as shown in Fig.3.8.

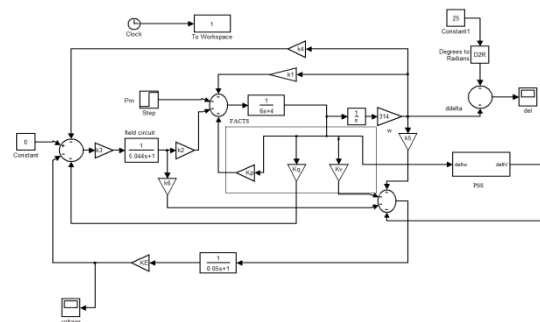



Fig. 3.8 Simulation Model for SMIB with Hybrid Power Flow Controller

The model in Fig.3.8 has been analyzed for stability studies by subjecting to small disturbance by varying the mechanical power ΔP_m and exciter gain K_E .

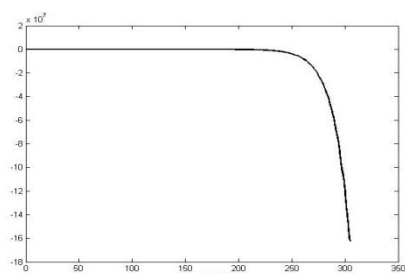

Fig. 3.9 Variation of Terminal Voltage for $K_E=1$ with $\Delta P_m=100$ $K_{HPFC}=1$

Fig.3.9 shows variation of terminal voltage when subjected to small disturbance of mechanical power (ΔP_m) = 0.01 p.u. with Exciter gain (K_E) = 1 and Hybrid Power Flow Controller (HPFC) is functioning and system become unstable. The system behavior in respect to system voltage is again obtained by increasing the value of $\Delta P_m = 100$ and $K_E = 1$ and found to be stable as shown in Fig. 3.10

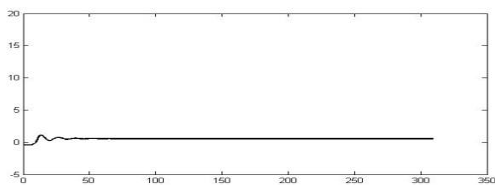

Fig. 3.10 Variation of Terminal Voltage for $K_E=1$ with $\Delta P_m=100$ $K_{HPFC}=10$

Similarly the variation of rotor angle with time has been plotted after subjecting the system with similar disturbances. Fig. 3.11 shows the variation rotor angle $K_E = 1$ and $\Delta P_m = 100$ and the figure depicts that the system becomes unstable. Fig. 3.12 shows the variation of rotor angle with $K_E = 1$ and $\Delta P_m = 100$ and the system is stable.

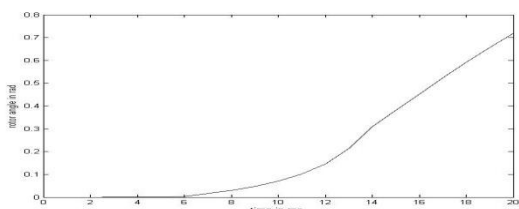

Fig. 3.11 Variation of Rotor Angle for $K_E=1$ with $\Delta P_m=100$ $K_{HPFC}=1$

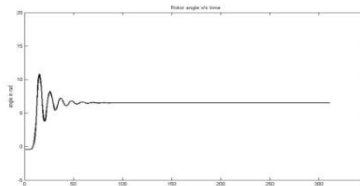

Fig. 3.12 Variation of Rotor Angle for $K_E=1$ and $K_{HPFC}=10$ with $\Delta P_m=100$

Analysis was done for various values of K_E varying from 0.01 to 100 and ΔP_m varying from 0.01 to 100 and tabulated in Table 3.2. Table 3.2 shows that with HPFC the system goes to instability for all values of ΔP_m . The exciter gain has to be same and increasing the value of HPFC gain thus damping has been improved to maintain the system stable.

Table 3.2 Peak overshoot and settling time of system voltage and Rotor angle with variation in mechanical power and Exciter gain incorporating HPFC

Mechanical Power ΔP_m in p.u.	Exciter Gain K_E	System Voltage		Rotor Angle	
		peak overshoot in p.u.	settling time in ms	peak overshoot in p.u.	settling time in ms
0.01	0.01	unstable	unstable	unstable	unstable
0.1	0.01	unstable	unstable	unstable	unstable
1	0.01	unstable	unstable	unstable	unstable
10	0.01	unstable	unstable	unstable	unstable
100	0.01	unstable	unstable	unstable	unstable
0.01	0.1	unstable	unstable	unstable	unstable
0.1	0.1	unstable	unstable	unstable	unstable
1	0.1	unstable	unstable	unstable	unstable
10	0.1	unstable	unstable	unstable	unstable
100	0.1	unstable	unstable	unstable	unstable
0.01	1	stable	stable	stable	stable
0.1	1	stable	stable	stable	stable
1	1	stable	stable	stable	stable
10	1	stable	stable	stable	stable
100	1	stable	stable	stable	stable
0.01	10	stable	stable	stable	stable
0.1	10	stable	stable	stable	stable
1	10	stable	stable	stable	stable
10	10	stable	stable	stable	stable
100	10	stable	stable	stable	stable
0.01	100	stable	stable	stable	stable
0.1	100	stable	stable	stable	stable
1	100	stable	stable	stable	stable
10	100	stable	stable	stable	stable
100	100	stable	stable	stable	stable

3.5 TRANSIENT STABILITY ANALYSIS



When a three phase short circuit fault occurs on power system, the machine accelerates and the loses its synchronism. If the fault is cleared at a particular time, the system retain its stability. The particular instant at which the fault may be cleared so that the system stability is maintained is known as the critical clearin time and the corresponding angle is called critical clearing angle. One of the most important tasks in transient stability assessment is the determination of the critical clearing time(CCT). HPFC installed on the system improves the critical clearing time(CCT) more effectively.

A fault has been incorporated in the system and the rotor angle variation are observed for different values of fault clearing time(FCT).

The values of the peak overshoot and the settling time of rotor angle for different values of fault clearing time is given in Table. 3.3.This is the case when HPFC is not incorporated in the system. Similar analysis has been done with HPFC incorporated in the system and values of peak overshoot is given in Table.3.4.

From Table 3.3. the critical clearing time (CCT) is 0.2848 seconds and the corresponding critical clearin angle is 15.8 degrees. From Table 3.4 critical clearing time (CCT) is observed to be 0.2938 seconds and critical clearin angle is 27 degrees. When HPFC is incorporated in the system , the critical clearing time (CCT) improves and then enhance the transient stability of the power system. Variation of rotor angle with time for fault clearing time(FCT) is equal to 0.2938seconds. When HPFC is incorporated in the system is shown in Fig. 3.10 Variation of rotor angle with time for the fault clearing time(FCT) equal to 0.3036 seconds is shown in Fig. 3.11.

Table 3.3 Summary of the observations in tabular form with variation in time without Kp, Kv, Kq

Fault clearing time in second	Rotor Angle	
	peak overshoot in degree	settling time in sec
0.0031	65	6
0.0151	60	6
0.0304	48	6
0.0474	36	5
0.0692	24	5
0.0999	15	5
0.1436	8.5	5
0.2052	6	5
0.2752	11	5
0.2848	15.8	5
0.3075	unstable	unstable
0.3721	unstable	unstable
0.4603	8.2	5

From above table critical clearing time is **0.2848** sec and corresponding angle is **15.8** degree. Before this value response of angle v/s time is stable and settled fast.

Table 3.4 Summary of the observations in tabular form with variation in time with K_p,K_v,K_q

Fault clearing time in second	Rotor Angle	
	peak overshoot in degree	settling time in sec
0.0031	68	8
0.0153	62	8
0.0305	50	6
0.0475	37	6
0.0695	25	6
0.1003	15	6
0.1442	8.5	6
0.2061	6.3	6
0.2762	11.7	6
0.2938	27	5
0.2958	unstable	unstable
0.3036	unstable	unstable
0.4605	9.2	5

From above table critical clearing time is **0.2938** sec and corresponding angle is **27** degree. Before this value response of angle v/s time is stable and settled fast.

CONCLUSION AND FUTURE SCOPE

CONCLUSION

A single machine infinite bus system has been considered for stability analysis simulation.HPFC is used for damping of power system oscillation in a single system. The performance of the proposed hybrid power flow controller is verified under different disturbances. Simulation results validate the robustness of the proposed control scheme. Moreover, this approach is also simple and easy to be realized in power systems. From above table critical clearing time is **0.2848** sec and corresponding angle is **15.8** radian without K_p, K_v, K_q. Before this value response of angle v/s time is stable and settled fast.From above table critical clearing time is **0.2938** sec and corresponding angle is **27** radian with K_p, K_v, K_q. Before this value response of angle v/s time is stable and settled fast.

Behavior of the SMIB system power system checked with HPFC connected and without HPFC, when system subjected to different kinds of small disturbances and results are presented in table 3.1 to validate the implementation of the HPFC model.

In the first case of the SMIB system was subjected to small disturbances by varying the mechanical input 0.01 p.u. In this case system bus voltage stability studies, it is observed from the plot peak overshoot reduces from 2.9 p.u. to 1.45 p.u., and settling time reduces from 250 ms sec to 160 ms.It is understood that bus voltage shows greater stability while increasing the HPFC gain from 1 to 20 with exciter gain of 100. Similarly behavior of rotor angle has been seen with same disturbances. It is observed from the graph, peak



overshoot reduces from 7.8p.u. to 6.52 p.u. and settling time reduces from 190ms to 130ms sec.

From the above results it is concluded that the action of HPFC definitely improves the system stability and damps the power system oscillations if HPFC parameters are selected carefully. Hence the stability of the system has been enhanced with the effective control of hybrid power flow controller.

This study shows the role of receding horizon principle based hybrid power flow controller in improving the transient stability of a very complex hybrid system with high nonlinearities and constraints. As the complete detailed dynamic machine model is considered, variation in all parameters can be observed and stability can be enhanced. Thus increasing demand and restriction on having additional new infrastructure, forces the existing power system network to work at its maximum possible limits.

This study presents a useful insight for power utility engineers to evaluate the application of HPFC and its impact on power system. HPFC is an advanced configuration that controls the operation of active and reactive power flow. HPFC will significantly extend the active power and reactive power flow capability and offer a great potential in solving many of the problems faced by the electric utility in a competitive environment. The simulation results prove the capability and performance of HPFC in dynamic control of power flow if A dynamic control strategy is developed in the boundaries of controllable range of HPFC to enhance the dynamic voltage stability.

4.2 FUTURE SCOPE OF THE THESIS

This model can also be used for Power System Analysis Software Package (PSASP). It can also be used with Power System Stabilizer (PSS). It can be used as MATLAB/SIMULINK hard-ware model. Further it can be extended with ANFIS. This can be further extended for GA and PSO to improve power system stability.

REFERENCES

- Kundur, P.; Paserba, J.; Ajarapu, V.; Andersson, G.; Bose, A.; Canizares, C.; Hatziargyriou, N.; Hill, D.; Stankovic, A.; Taylor, C.; Van Cutsem, T.; Vittal, V.; "Definition and Classification of Power System Stability", IEEE Transactions on Power Systems Vol. 19, pp 1387 – 1401, 2004.
- Shahgholian, G.; Shafaghi, P.; Moalem, S.; Mahdavian, M.; "Damping Power System Oscillations in Single-Machine Infinite-Bus Power System Using a STATCOM" International Conference on Computer and Electrical Engineering, ICCEE. Vol1, pp130 – 134, 2009.
- Gurralla, G.; Sen, I.; "A Modified Heffron-Phillip's Model for the Design of Power System Stabilizers" Joint International Conference on Power System Technology and IEEE Power India Conference, POWERCON, pp 1 – 6, 2008.
- Zarringhalami, M.; Hakimi, S.M.; Javadi, M.; "Optimal Regulation of STATCOM Controllers and PSS Parameters using Hybrid Particle Swarm Optimization" 14th International Conference on Harmonics and Quality of Power (ICHQP), pp 1 – 7, 2010.
- Praing, Ch.; Tran-Quoc, T.; Feuillet, R.; Sabonnadiere, J.C.; Nicolas, J.; Nguyen-Boi, K.; Nguyen-Van, L.; "Impact of FACTS Devices On Voltage And Transient Stability of a Power System Including Long Transmission Lines" IEEE Transaction on Power Engineering Society. Vol. 3, pp1906 - 1911, 2000.
- Khuntia, S.R.; Panda, S.; "ANFIS Approach for TCSC-based Controller Design for Power System Stability Improvement" IEEE International Conference on Communication Control and Computing Technologies (ICCCCT), pp 149 – 154, 2010.
- Swaroopan, N.M., Somasundaram, P.; "Transient Stability Enhancement with UPFC" International Conference on Information and Communication Technology in Electrical Sciences ICTES, pp510 - 516, 2007.
- Behar, B. Lamnabhi-Lagarrigue, F. Ahmed-Ali, T.; "Robust Nonlinear Control of Transient Stability of Power Systems" IEEE Conference on Decision and Control, Vol. 1 pp294 - 299, 2003.
- Wagh, R.; Kamath, A. K.; Singh, N.M.; "Non-linear Model Predictive Control for Improving Transient Stability of Power System using TCSC Controller" Asian Control Conference, ASCC pp1627-1632, 2009.
- WuZhongxi; ZhouXiaoxin "Power System Analysis Software Package (PSASP)- an Integrated Power System Analysis Tool International Conference on Integrated Power System Analysis Technology, Vol-1, pp 7-11, 1998.
- Abdul-Malek, M.A.; Abido, M.A.; "STATCOM based Controller Design using Particle Swarm Optimization for Power System Stability Enhancement" IEEE Transaction on International Symposium Industrial Electronics, ISIE, pp 1218 – 1223, 2009.
- Suresh, Y.; Panda, A.K.; "Dynamic Performance of STATCOM Under Line to Ground Faults in Power System Power Electronics". International Conference on Machines and Drives (PEMD 2010), pp1 - 6, 2010.
- Lerch, E.N.; Povh, D.; Xu, L.; "Advanced SVC Control for Damping Power System Oscillations" IEEE Transactions on Power Systems, Vol.6, No. 2 pp 524 – 535, 1991.
- Poshtan, M.; Singh, B.N.; Rastgoufard, P.; "A Nonlinear Control Method for SSSC to Improve Power System Stability." International Conference on Power Electronics, Drives and Energy Systems, PEDES, pp 1 – 7, 2006.
- Zhang, X.C.; Cheng, G.H.; Xu, Z.; "User Defined Excitation System Models for Power System Stability Analysis" Transmission and Distribution Conference and Exhibition: Asia and Pacific, in PSASP pp 1 - 5, 2005.
- Rai, D.; Faried, S.O.; Ramakrishna, G.; Edris, A.; "Hybrid Series Compensation Scheme Capable of Damping Subsynchronous Resonance" IET Proceeding on Generation, Transmission & Distribution, Vol. 4, No. 3 pp 456 - 466, 2010.
- Senjyu, T.; Yamane, S.; Uezato, K.; "Enhancement of Power System Stability with FACTS using Adaptive Fuzzy Controller Systems", IEEE International Conference on Man, and Cybernetics, Vol. 6, pp 533 – 538, 1999.
- Alam, A.; Abido, M.A.; "Parameter Optimization of Shunt FACTS Controllers for Power System Transient Stability Improvement" IEEE Power Tech conference, pp 2012 – 2017, 2007.
- Chandrakar, V.K.; Dhurvey, S.N.; Suke, S.C.; "Performance Comparison of SVC with POD and PSS for Damping of Power System Oscillations" International Conference on Emerging Trends in Engineering and Technology (ICETET), pp247 - 252, 2010.
- Bebic, J.Z.; Lehn, P.W.; Iravani, M.R.; "The Hybrid Power Flow Controller - A New Concept for Flexible AC Transmission" IEEE Power Engineering Society General Meeting, 2006.